



**THE INTERNATIONAL
QUARAB HORSE
ASSOCIATION**
Book of Rules and Regulations 2004

GENERAL

Name:

This organization shall be called the INTERNATIONAL QUARAB HORSE ASSOCIATION. The official abbreviation shall be IQHA.

Purpose:

To maintain and service the registry for the Quarab breed. It shall further promote the responsible breeding of Quarabs by specific pedigree, conformation type and performance, as well as promoting interest in the Quarab as a breed. The members shall be encouraged to promote Quarab classes in all type of horse shows where possible and should promote good horsemanship and sportsmanship.

Members:

Membership is open to all qualified persons interested in the purpose of this organization.

The Business Office:

A Business Office shall be established and all business of the Association will be conducted through this office. All normal business will be under the supervision of the Registrar. The location of this office shall be determined by the Registrar.

Satellite Offices:

Satellite offices will be encouraged. Such title shall be issued and revoked at the sole discretion of the Registrar.

Membership:

The membership shall be further defined in the Membership Rules and Regulations and may be changed or modified from time to time.

Official Newsletter:

The Registrar may cause to be published a quarterly newsletter which will be the official voice of the IQHA. The method and place of publication will be at the sole discretion of the Registrar.

NOTE

Situations not specifically covered in this Rule Book will be managed according to current IQHA policy. All changes made after the publication of this book will be published in the IQHA newsletter as official Rule Book changes.

MEMBERSHIP RULES AND REGULATIONS

RULE 1

Application for Membership

Application for membership must be made in writing to the IQHA Business Office upon blank furnished by the organization or downloaded and printed from the Quarab.org website, and shall be in such form and on such conditions, and while in good standing, shall entitle the member to all privileges and advantages of membership. By applying for membership, the applicant automatically agrees to be bound by and to abide by the Rules and Regulations of the Association.

RULE 2

Memberships

Four types of Memberships are offered:

- a. Youth
- b. Individual
- c. Family
- d. Lifetime, individual only

RULE 3

Authorization

Legal partnerships, corporations and individual Membership shall specify in writing the person(s) authorized to act in their behalf or to sign registrations and transfer applications. The signature(s) of authorized person(s) in all instances shall be included with the authorization.

RULE 4

Transfer of Membership & Membership Name Change

A member is non-transferrable except in case of the following:

- A. Any person who changes marital status shall have thirty (30) calendar days to update their membership. Failure to update applicable membership shall render any points earned after the thirty (30) days null and void. It is necessary for the owner to have all Quarabs in their possession transferred upon the Association records to correspond with the new title/name.

In the case of the death of a member. The Membership may be transferred to the member's legal heir. This does not apply to the children or heirs of a lifetime Membership.

Only one such change per Membership will ever be made.

**RULE 5
Fees**

- A. Membership is currently based on a 12 month year. One subscription to the Quarab Quarterly newsletter is included with paid Membership. A newsletter may be purchased separately (without Membership).
Individual: Includes one individual age 18 years or older only.
Youth: Individual age 18 & under.
Family: All individuals living in a single household, including up to two (2) adults and all youth under the age of 18, also used for "and" & "or" Memberships of non-related persons (one newsletter subscription).
Life: Single Membership listing (individual or in the case of "and" Membership such as "John AND Jane Doe).

All signatures are required on all membership applications.

- B. When a request is received to cancel and refund or credit the applicable fee for any work on which processing has begun, a non-refundable office processing fee will be withheld from the requested refund/credit. (See current fee schedule).

Failure of any individual to acknowledge and respond to any IQHA correspondence regarding application for Membership, transfer or registration of a Quarab, or any other IQHA business will result in that file being closed. Two (2) notices will be sent to the address included with application or transfer. Thirty (30) days after the second notice has been sent, if there remains no reply, the file will be Dead Filed. An inactivated file may be reopened if the following requirements are met:

- a. payment of the appropriate member's current membership fee.

- b. submission of requested, necessary or missing documents, signatures or pictures as included in the notification.
- c. payment of applicable fees, for registrations, the increased fee for the adjusted age of the horse will be required.

**RULE 6
Television and Media Rule**

- a. Attendance at an IQHA-approved event, in whatever capacity shall constitute authorization for IQHA, its agents, designees, or assigns to photograph, video, tape, televise, or record by other means (hereinafter referred to as "photographic material") any person or Quarab on the premises of a IQHA-approved event, and shall further constitute authorization for the use of such person's name, voice and biography, or the name, pedigree and performance record of any Quarab on the premises (hereinafter referred to as "related information") in conjunction with any photographic material.
- b. The photographic material and related information referred to above may be used in any manner that the IQHA, at its sole discretion, determines would be beneficial to promoting purposes and goals of the IQHA; provided however that no photographic material or related information will be used in conjunction with the endorsement of any product unless prior written consent is obtained.
- c. Attendance at a IQHA-approved event shall further constitute agreement to the terms and conditions outlined above and shall constitute a waiver and release without limitation of any individual television, radio, motion picture, photographic or other similar rights, including right of privacy any person or Quarab may have in or to such photographic material or related information when such information is obtained at a IQHA-approved event by the IQHA, its agents, designees or assigns.

**RULE 7
Responsibility**

- a. The International Quarab Horse Association will not assume the responsibility of settling

- civil disputes concerning financial settlements, ownership, health or fertility.
- b. No person shall refuse the reasonable request to assist the Association, its officers, committees or agents in locating, identifying and inspecting, or to answer promptly and truthfully any inquiry concerning an animal or ancestor thereof in their ownership or control, which has been registered or listed, or for which application to register or list has been made. A violation of this rule may be grounds for disciplinary action.
 - c. In the furtherance of their official duties, all Association representatives shall be treated with courtesy, cooperation and respect and no person shall direct abusive or threatening conduct toward them.
 - d. All information furnished to the Association as a basis for any action by the Association or any of its officers shall be true and correct. This includes, but is not limited to, membership applications, registration applications, application for show approval, and all information in regard to Association investigation of third parties.
 - e. Accuracy of records furnished by the Association, either as hard copy or by email communication, is warranted by the IQHA only to the extent of using its best efforts in the compilation thereof and then solely for the benefit of the member party purchasing the record. Reimbursement of the expense of the record on a showing of material inaccuracy is the sole remedy available to anyone receiving inaccurate information of the Association. Consequential damages are expressly excluded. No warranties, express or implied, arise from records issuance, other than as stated therein, as the purchaser receives this recorded on an "as is" basis. For absolute accuracy, independent verification must be obtained from the current owner or their predecessor in title to the subject horse.
 - f. In all proceedings concerned with or affecting the registrations and records of the Association and in all disciplinary actions, the burden of resolving any doubts as to the true parentage or identification of an animal, or qualification for registration (either by pedigree or inspection) shall be upon the

owner, lessee or other member(s) or non-member(s) involved. The determination, decision or action of the Executive Committee upon all such shall be final and binding upon all parties. As the owner has the burden by failure to present evidence concerning such questions to the Association at a hearing scheduled to resolve the question, the owner shall be deemed to have waived their right to later present such evidence to a court of law, if he seeks judicial review of the Association's action.

- g. When an exhibitor, owner or trainer is guilty of unsportsmanlike conduct, such person is subject to disciplinary action by the IQHA, including, but not limited to, fines of suspension.

RULE 8

Liability

The IQHA, its satellite officers, directors, members of committees, inspectors, employees, representatives and agents will attempt to obtain true and complete in connection with registration of Quarab horses, transfer or registration certificates, hearing and all other matters relating to IQHA activities. Except for proven wrongdoing, neither the IQHA nor its officers, directors, members of inspectors, employees, representatives nor agents will be liable in any way, whether in damages or otherwise, for issuance of any pedigree certificate, for the transfer of any pedigree certificate, for the cancellation of any pedigree certificate, for the refusal to issue a pedigree certificate, for the issuance of any pedigree statements, for the refusal to transfer any pedigree certificate, for any disciplinary procedure brought against or penalties imposed on any member or any person or for any other activities engaged in, by or on behalf of the International Quarab Horse Association.

RULE 9

Release of Liability

The IQHA and co-sponsoring organizations, if any, shall not be responsible for any personal injury, or for loss or damage to property, occurring at any IQHA activity. Each owner, exhibitor, handler or consignor shall indemnify and hold harmless the IQHA, its officers, directors and employees from and against all claims, causes of actions, and expenses of every

kind, including attorney's fees, of or related in any matter to the acts or omissions of an owner, exhibitor, or consignor, or the actions of any animal under the care, custody, or control owner, exhibitor, handler or consigner. Presentation of signed entry or consent forms shall be deemed acceptance of the conditions of this rule. In the event of consignment form is not signed or presented, appearance on the grounds or at the sale ring of any IQHA activity as an exhibitor, handler, owner or consignor shall be deemed to be acceptance of the conditions of this rule.

RULE 10 IQHA Funds

A. Any and all fees or moneys due the IQHA are the property of the IQHA upon collection and shall be turned over to the Association within thirty (30) days of collection. The officers of such club and/or individual shall be personally liable and, in addition, subject to the rules pertaining to violations and disciplinary procedures.

B. Any and all fees or moneys due IQHA must be paid in U.S. funds only.

RULE 11 Violations

a. Any member may be suspended and denied privileges of the Association and any non-member may be denied the privileges of the Association for the failure to pay when due any obligation owing the Association, including the Quarab Quarterly newsletter, or to an approved show, or for giving a worthless check for entry fees, stall fees, office charges, stock charges or any other fees or charges including bank charges for returned checks connected with the exhibition of horses, or for failure to time file with the Association required annual stallion breeding reports, or any related fees. Fourteen (14) days before action by the Registrar, written notice of the account due or delinquent stallion breeding report and the intention to suspend or withhold privileges of the Association shall be mailed to such member or non-member. Upon suspension by the Registrar, the name of the member or non-member may be published in the Quarab Quarterly, beginning with the next available issue from date of suspension. Any suspension and denial of privileges of the Association under this section shall

terminate upon full payment of the obligations due the Association or filing of the requisite stallion breeding report.

- b. When any person is guilty of the following: failure to pay when due any obligation owing to the Association, giving a worthless check for entry fees, stall fees, office charges connected with the exhibition of horses, such person, whether member or non-member, will be subject to disciplinary procedures insofar as practical.
- c. Every member and every non-member who violates in any manner the Constitution, Bylaws, or Rules and Regulations of the association, whose practices in the breeding of the Quarab horses or in supplying information for the Association's records or whose conduct has endangered or may endanger in good order, welfare or credit of the Association, or who is convicted in a court of law for cruelty to animals and upon submission of certified evidence of such conviction from any court, may be censured, suspended or, in the case of a member, expelled from membership in the Association and denied all privileges of the Association including, without limitation of the generality of the foregoing, the privilege of registrations or change in ownership of Quarab horses on the records of the Association by the Registrar.

RULE 12 Fraudulent Practices

- a. No person shall represent any animal owned or managed by him to be registered with the IQHA when its not.
- b. No person, firm or corporation shall issue, sell, exchange, give away or receive, or offer to any thereof, any false or fraudulent certificate representing same to be genuine official certificate issued by the Association.
- c. No person shall advertise, or enter in any Quarab horse event or competition any Quarab registered with the Association by a name other than that by which it is registered or listed.
- d. No change in or alteration of a certificate of registration or listing or identification required by the Association shall be made

except by the Association or its official representative/satellite office upon proper showing of the necessity for such change or alteration by reason of change in color or markings, mistake or the like; nor shall any person display or advertise or have in their possession any such certificate that has been changed or altered otherwise, other than by the Association or on its authority.

- e. No person shall alter in any way, change or attempt to hide or alter the natural markings of a horse, by surgery, dye or in any other manner.
- f. No person shall represent as a registered Quarab horse any horse other than the horse for which said certificate was issued.

RULE 13

Disciplinary Procedures

- A. Any member may be disciplined, suspended, fined or expelled from the Association, and any member or non-member may be denied any and all privileges of the Association, or any registration certificate may be cancelled whenever it shall have been established by satisfactory evidence that such member or non-member has violated any Bylaw, Rule or Regulation of the Association.
- B. The Registrar, his staff and designees shall have sole authority to investigate possible or alleged violations of any Bylaw, Rule or Regulation of the Association. In order for complaint other than one which can be verified by credible testing, to be considered for investigation, it must be in writing, signed and dated. The individual(s) filing the complaint must be prepared for full disclosure of the complaint to the party (parties) concerned in the complaint and must be prepared to appear at a hearing if it is deemed necessary .
- C. When it is determined that there is sufficient cause for a hearing, the person charged with any alleged violation shall be given not less than thirty (30) days' notice of a time and place for hearing such allegations by the Registrar, at which time and place he shall have the opportunity, in person.

RULE 14

Registration

Eligibility:

- A. Both the sire and dam must be registered with IQHA or an approved outcross breed registry AND
- B. Any sire registered with an approved outcross breed must also be listed with IQHA for his 2001 and alder foals to be eligible for registration.

NOTE: Effective 01/01/00, NO IQHA eligible stallions will be accepted for listing with IQHA. Such stallions will have to be registered with IQHA. Stallion Breeding Reports are required and must be submitted by stallion owners for all stallions registered OR listed with IQHA.

- C. 2001 and after foals produced out of IQHA eligible mares will be assessed an additional Mare Penalty (i.e. Hardship) fee if said mare is also not registered with IQHA.
- D. Stallions with unknown, undocumented or unregistered (approved outcross registry) parentage or background are NOT eligible for IQHA registration.
- E. **HARDSHIP:** Stallions with at least 75% documented pedigree (approved outcross registry) are eligible for IQHA registration when approved by the Registration Committee. Mares and geldings with at least 50% documented pedigree (approved outcross registry) are eligible for IQHA registration when approved by the Registration Committee.
- F. **REGISTRATION COMMITTEE:** has the power to approve a horse for IQHA registration on Hardship i.e. if the horse exhibits excellent breed type. The Registration Committee reserves the right to refuse a horse for IQHA registration on Hardship based on the horse not displaying excellent breed type.
- G. **GRANDFATHER CLAUSE:** Available to horses whose sire and dam are both registered with IQHA or an approved outcross breed. The Grandfather Clause form of registration waives the normal necessity of Stallion Listing, Stallion Breeding Report, Mare Penalty etc. as outlined above, and is

only available to current members or those applying for membership.

“Breeding Stock” division registered horses.

RULE 15

Acceptable Outcross Breeds/Registries

The following breeds/registries are recognized by the IQHA as outcrosses. Individual cases involving breeds that are not on this recognized list will be considered and acted upon by the IQHA business office.

A. Quarab Horses

- a. UQR- United Quarab Registry, at this time, UQR registered horses are encouraged to cross register with IQHA but are approved as a source of IQHA blood
- b. IAHA- International Arabian Horse Association, eligible horses must be cross registered with IQHA to continue producing registered offspring with the IQHA, however their IAHA certificate with pedigree shall be considered adequate documentation of such for the purpose of pedigree verification.
- c. AIR- Arabian International Registry Partbred division (formerly PARONA) eligible horses must be cross registered with IQHA to continue producing registered offspring with the IQHA, however their AIR certificate with pedigree shall be considered adequate documentation of such for the purpose of pedigree verification.

B. Pleasure Type Outcrosses

Purebred Arabian stallions and mares of the following registries are eligible to produce registered Quarabs:

- a. AHRA- Arabian Horse Registry of America
- b. AIR Arabian International Registry, formerly (IAHRONA)
- c. Any foreign Purebred Arabian Registry/studbook that is currently recognized by the AHRA or WAHO

C. Stock Type Outcrosses

Purebred Paint and Quarter Horse stallions and mares of the following registries are eligible to be parents of registered Quarabs:

- a. AQHA- American Quarter Horse Association
- b. APHA- American Paint Horse Association, there shall be no bias toward “Regular” registered horses vs.

d. Other

Parentage of strictly Arabian, Paint or Quarter Horse blood/pedigree in IQHA defined proportions may be found in other registries, these horses will be evaluated on a case by case basis by the IQHA business office. Some examples include:

PtHA- Pinto Horse Association of America registered animals, although those that are eligible for IQHA registration themselves must be IQHA registered. These horses may be Stock or Pleasure Type depending on their pedigree.

JC- Jockey Club, due to certain situations regarding Appendix Registered animals in the APHA and AQHA and those horses registered twice by the JC and the APHA, some Quarabs may have a JC registered parent or grandparent, these horses will be evaluated for Quarab Breed Type on an individual basis before registering them.

RULE 16

Requirements for ALL Registrations

- a. All Registration Applications must be accompanied by 4 current color photos of animal, approximate size 3 x 3. These views shall include: one (1) Full frontal view (head on), two (2) Full side/profile views of left and right sides (one each), and one (1) Full rear view. All photos should include all parts of the animal available in that view (i.e. ears to hooves or nose to tail) and be unobstructed by other animals, riders, fences or foliage in the foreground. For pinto marked animals, additional close ups should be submitted to show color not evident in the four (4) required views (i.e. white underjaw, belly white, minimal white spot). Each photo should be labeled with the first name choice and owner’s last name.
- b. Copies of outcross registration papers submitted in lieu of breeder’s certificate must show the same ownership as the one applying for.

A copy of the sire's/dam's papers has to be included if either parent is not registered or listed with the IQHA or instead of a copy of the animal's outcross registration certificate. **NO ORIGINALS FROM OTHER REGISTRIES SHOULD BE INCLUDED.**

Fees paid to IQHA are not refundable, including registration fees, if the animal is eligible for any of our registry classifications. A \$5.00 processing fee will be retained by IQHA on all cancelled or uncompleted work. IQHA reserves the right to classify and register based on the information and photos received with the initial application.

Registration applications must be completed in entirety and submitted with all fees, applications, photos and documentation necessary as outlined herein. Incomplete applications maybe subject to lengthy delays in processing and possible additional fee assessments.

Allow at least four (4) weeks for processing work submitted to IQHA. Registrations needed in a shorter time frame should be marked accordingly and accompanied with the Rush Fee.

Contact IQHA office for details regarding Herd Package discounts or any other questions regarding registration.

RULE 17

IQHA Registration Fee Structure

**These rates are applicable only to current or applying members when completed registration application is received at IQHA office with all required fees and photos.

Weanlings of current year: \$10.00*

Yearlings and Geldings of all ages: \$15.00*

Stallions & Mares over 1 year: \$20.00*

Grandfather Clause (for qualifying mare or stallion any age) \$10.00

IQHA Dual Registration for UQR registered horses: \$ 5.00

Stallion or Mare listing (requires different application form): free for members

Hardship Fee: \$30.00

Hardship includes:

1. Horses not having both parents registered with IQHA or an approved outcross breed.
2. Failure to submit or lack of necessary documentation as required and/or requested (as previously outlined)

Rush Fees:

Time calculated from date work and fees are received by IQHA until date work is mailed from IQHA office. Rush registrations and all associated fees must be paid via Cashier's Check or Money Order and envelope & application marked 'RUSH'

7 Working Day Rush: \$10.00

72 Working Hour Rush: \$20.00

Return via Express Mail: \$20.00

**Non-members includes additional fees and forms for pertinent membership or pay additional non-member fee of \$25.00

(Note: IQHA accepts duplicated copies of all IQHA copied in entirety. **IMPORTANT:** All registrations are subject to further investigation and review at the IQWHA Business Office. Color qualifications will be determined by and must be evidenced by photos submitted to the office. The IQHA Business Office will make final determinations of eligibility. All registrations subject to review and cancellation at any time.)

***Any horse with one or both parent registered with IQHA may deduct \$5.00 from the listed fees.**

*** International fees must be sent in US Dollars with additional \$3.50 to any one (1) fee for the cost of additional postage (not to EACH fee).

RULE 18

Coat Color and Markings

IQHA accepts all coat colors.

Patterns of white recognized by the IQHA include the following: Tobiano Overo Tovero Grey Roan

Eyes, Skin

No discrimination is made concerning light or dark skin, or against blue, glass, hazel or dark eyes.

Quarabs exhibiting the Tobiano, Overo or Tovero patterns may display multi-colored hoof markings.

RULE 19

Listing of Outcross Breeds

A. Listing

1. All approved outcross stallions and mares shall be listed with the IQHA prior to the registration of their 2004 and after foals and shall meet the IQHA pedigree and documentation requirements.
2. Listed horses are not eligible to enter approved IQHA show classes except for breeding stock classes especially designated for "purebred" outcross stock.

B. Procedure

1. There is no fee for this listing.
2. Listing is available only to current members or those applying for membership.
3. A listing application shall be submitted along with a complete copy of the horse's registration papers and authorized signatures.
4. Listing is beneficial to the horse's owner because it gives IQHA the correct pedigree, breeding and authorized signatures for the animal. Listing also alleviates the need to send copies of the horse's registration papers for the registration of each offspring.
5. If the listed horse is transferred, the signature of the new owner must be submitted to the business office. Please submit a new listing form and a copy of the horse's registration papers showing new ownership OR a signed IQHA transfer.
6. There is no fee for the transfer for current or applying members.
7. Except in the case of a transfer of ownership, an animal only needs listing one time for the lifetime of the animal.

C. Alternative - Grandfather Clause

Individuals registering their own animal(s) out of unlisted animals with the submission of properly signed Breeder's Certificate, a copy of both parents' registration papers and proper fees. After 12/31/2004, this alternative shall constitute a Grandfather

Clause and will require additional fee of \$10.00.

RULE 20

Breeding Restrictions

- A. Horses displaying known genetic faults shall not be used for breeding purposes: Parrot Mouth, Cryptorchidism
- B. Horses with line(s) tracing to the QH Impressive shall have on file genetic testing for either themselves or the parent with that line showing a N/N test for HYPP. Animals with N/H or H/H are not to be used for producing Quarabs.
- C. It is strongly encouraged that TB influence is kept to a minimum in the pedigrees of Quarabs. *A limitation on the percentage of TB blood will begin in 2004 (amount yet to be determined).* Horses already registered with the IQHA shall retain their papers even if over this limit, but no new registrations shall be accepted.
- D. Any known blood from non-accepted outcrosses is prohibited. Hardship horses may not be registered with KNOWN pedigree from animals outside of the outcrosses listed as approved.
- E. IQHA does not accept any of the appaloosa coat patterns as acceptable body white; any Quarab developing such characteristics after registration is subject to cancellation of registration papers.

RULE 21

Naming A Quarab

- A. Three names must be submitted with each application for registration.
- B. IQHA reserves the right to deny a name for any of the following reasons or for any name that does not fall into one of the categories but is felt to be inappropriate for a family-oriented organization.
The following names are unacceptable for use:
 1. Names already in use.
 2. Names that are obscene or vulgar in nature or of an offensive nature.

- C. Translation of any name containing a foreign word or words must accompany the application.
- D. Names must not contain numbers, Roman numerals, diacritical marks nor punctuation other than an apostrophe or an ampersand (&).
- E. Names may not exceed 22 letters and spaces (including punctuation).
- F. If all name choices are unacceptable, owner has the option to allow IQHA to make a name choice or delay registration completion until IQHA can make contact via written notification to request an additional name choice (may be done via email).

RULE 22

Name Change

Once a registration certificate has been issued, any change to the registered name of the animal will constitute a name change and subject to the following:

- A. No name shall be changed on a horse once it has registered offspring or once it has attained an extensive performance record.
- B. Name may be changed upon written request and submission of the original registration certificate, new name choice and the appropriate fee (\$ 10.00).
The fee is refundable if the name change is not approved.

RULE 23

Breeder

The breeder of a horse shall be the recorded/ documented owner of the dam at the time of breeding, except when said mare has been leased (and written notification of such has been submitted to the IQI-IA). In the event of such a recorded lease, the lessee at the time of breeding shall be listed as the breeder.

RULE 24

Breeder's Certificates

- A. A completed breeder' s certificate, signed by the recorded owners/lessees (with copy of lease for either/both on file with the business office) of the sire and dam at time of service. must be submitted with registration application.

- B. There shall be no alterations to the information given on the breeder' s certificate; certificates with any changes or additions shall not be acceptable for the purpose of registration.
- C. A copy of the animal' s outcross registration papers may be submitted in lieu of a breeder' s certificate.
- C. In the case of Hardship registration when signatures of the sire or dam are unavailable, and other proof of pedigree is unavailable/ not furnished, pedigree given will be listed as "not proven" or "unknown".
- E. A mare serviced by more than one stallion during the season must have a breeder' s certificate signed by the owner of each stallion, giving dates of service.

RULE 25

Stallion Breeding Reports (SBR)

- A. On or before 12/31 of the breeding year, owners, lessees or acting agents of any registered Quarab stallion, or listed outcross stallion must submit, with the appropriate filing fee (\$10.00), a stallion breeding report listing all mares bred to said stallion during that year. This report must be complete with all mare' s registered names, registration numbers, owner name(s) and dates exposed & how bred as well as the stallion owner' s signature.
 - 1. All mares exposed to the stallion should be listed even if not confirmed in foal.
 - 2. Only mares that will produce an eligible IQHA foal need be listed. For example, a purebred Arabian stallion need not list purebred Arabian mares but must list ALL Quarter Horse, Paint & Quarab mares exposed to him.
- B. A late fee shall be required for any SBR filed after the 12/31 deadline. The late fee shall be in the form of a per mare assessment of \$3.00.
- C. All previous year' s stallion breeding reports on newly listed outcross stallions may be submitted with initial listing with no late fee/mare assessment fees. One SBR per year, listing all mares exposed (as above) for each

year to be submitted with the initial listing application. There is a one-time \$10.00 filing fee regardless of the number of stallion breeding reports tiled at that time.

- D. It is helpful to submit a copy of each mare' s registration certificate with the SBR. If this is done, stallion owner/lessee/agent will receive Registration Applications for each mare' s foal with the breeder' s certificate section completed and ready for authorized signatures. Additional copies of the mare(s) registration certificate(s) will then not need to be sent with their foal' s registration application.

RULE 26

Managerial Agreements/Agent

- A. The owner of any horse. Quarab or outcross, may authorize another party to sign all pertinent documents for said horse for the purposes of:
 - 1. Showing
 - 2. Breeding/Breeder' s Certificates
 - 3. Filing Stallion Breeding Report
- B. A listing form (mare or stallion) is to be used to file such authorization with the business office. The registered owner of the horse may rescind this authorization at any time upon written notification being sent to the business office. The listing form must be complete upon its arrival in the office, including the full name and registration number of the horse, and full names and addresses of all parties involved as well as the individual, written signatures as they are to be recognized on official documents.

A managerial agreement is valid only when the animal remains in the physical custody of the owner or with an employee of the owner (direct employee or trainer, boarding stable). if the horse is in the physical custody of another that is not in the employ of the owner, this will be considered a lease and appropriate form and fee must be submitted the office.

RULE 27

Surrender of Certificate

The owner of any registered animal which dies or is sold/ disposed of without papers, shall notify the IQHA of the fact and surrender the appropriate registration certificate to the office for proper notation. If requested, the canceled certificate will be returned to the owner.

RULE 28

Artificial Insemination

Any stallion owner or agent failing to comply with the requirements listed below may be subject to disciplinary action by the IQHA Board.

If, in the opinion of the IQHA Board and/or

Registrar, there is justifiable cause to question the parentage of a foal resulting from artificial insemination, the Board may require the foal, sire and or dam to be blood typed/DNA typed if a pedigree is to shown as proven on the registration certificate. Such blood/DNA typing shall be done by an organization approved by the IQHA at the expense of the foal owner. The results of this test, along with other documentation provided by the foal owner, may be taken into consideration by the Board in determining the foal's parentage as recognized by the IQHA.

RULE 29

Embryo Transfer

In regard to a horse foaled by a mare which is not its genetic dam. but transferred to her via an embryo transfer procedure eligible for registration provided that it meets all IQHA rules and regulations for registration. All usual paperwork is required and Blood/DNA Typing may be required at the expense of the foal owner (see Artificial Insemination).

RULE 30

Age of the Horse

The age of a horse shall be computed by the calendar year starting on January 1 of the year foaled, i.e. it is a weanling during the calendar year in which it was foaled regardless of actual foaling date. A horse shall be considered 1 year old on the January 1st immediately following its foaling,

SHOW APPROVALS

RULE 31

Transfer of Ownership

Any seller (owner of record at time of sale) shall have the responsibility for completion of the written transfer in its entirety, on a form acceptable to the IQHA and for delivery of it to the IQHA.

The seller is responsible for the completion of the transfer; including the correct name and registration number of the horse, date of sale, name and address of the buyer, and signature and address of the seller and shall deliver the transfer along with the original registration certificate and required fee to the IQHA. Actual payment of the fee to be determined by the individual parties involved.

In the event the horse is sold via an auction, the seller may deliver to the management of the auction the original certificate of registration and the transfer completed as possible with the instruction to complete the transfer and send certificate of registration, transfer and fee to the IQHA upon completion of the sale. Ultimate responsibility for completion and delivery to the IQHA continues to remain with the seller. Two current photographs must accompany the transfer.

Should the owner of the of registered horse sell a horse and fail to complete the transfer form and this fact is established, the seller may be subject to disciplinary action by the Board of Directors and such violations shall be published.

* Exception: animal sold/disposed of without papers – certificate of registration shall be send to the IQHA for such notification.

RULE 32

Violations

No person shall refuse, on reasonable request, to assist the Association, its officers, committees or agents, in locating, identifying and inspecting, or to answer promptly and truthfully any inquiry concerning an animal or an ancestor thereof in his/her ownership or control, which has been registered or listed or for which application for registration has been made.

RULE 33

A. Registration

Only IQHA-registered horses may enter and compete in IQHA-approved shows and classes. The exhibitor must be able to prove that the horse is properly registered with IQHA by showing original registration papers, a photocopy of both sides of original registration papers, official Conditional Registration Certificate, or a current type designation card. A Show Committee must request such proof of registration upon entering. No entry listing a Quarab as “unnamed” or “pending” may be accepted by a Show Committee. Every entry must be entered under its full registered Quarab name and number as shown on its papers.

Show Committees submitting results with any Quarab listed as “unnamed” or “pending” may be reprimanded and/or fined by IQHA. IQHA reserves the right to disqualify any “unnamed” or “pending” entry from a class.

B. Application

1. Organizations, clubs, or individuals wishing to sponsor shows which will be recognized by IQHA must obtain the approval of IQHA.

2. An Application for Show Approval form shall be secured from IQHA, properly completed and submitted to the IQHA business office a minimum of one hundred twenty (120) days prior to the first date of any proposed show.

3. All applications and plans for the show must conform to the complete IQHA Quarab Show Rules as set forth in this rule book. The correctness of the class list as submitted to IQHA is the responsibility of the Show Committee. IQHA is not responsible for any errors or omissions on such list.

4. Priority for a show will be offered to a group that desires renewal of the show for the same time period year-to-year, assuming approvals are consistent with all applicable IQHA rules. To receive priority, the show application must be received by November 30.

5. Back-to-back shows (one complete show on Saturday and one complete show on Sunday) and multi-judge shows (two or three judges in the ring working independently) are each separate shows and must have separate applications.

6. The charter president or authorized representative must approve all show applications in their area before they are submitted to IQHA.

Applications must not be signed unless the forms are complete and the premium list is enclosed. Sector Directors may sign as authorized representatives on show approvals for non-Quarab and/or open shows.

7. If the application is satisfactory, the IQHA business office will issue a statement of official approval. If the application is not satisfactory, the IQHA business office will so inform the organization or individual making application and give the reasons for disapproval.

8. IQHA reserves the right to limit the number of shows per calendar year sponsored by the same organization or management.

9. IQHA reserves the right to change, revise, subject, adjust, or update show approval and/or minimum requirements.

10. The show approval fees will be assessed based on show structure.

Contact IQHA for fees.

a. Single judge open show - 4 classes minimum, 10 classes maximum

b. Single judge show

c. Multi-judge show (two judges)

d. Multi-judge show (three or more judges)

e. Area Championship Show

f. Futurity, per judge

Copies of all futurity rules and regulations must be sent with the application.

All show applications must be received by December 31 of the previous year

at the current show approval fees. Any show application not submitted by December 31 will be double the original fee.

11. Show results processing fees will be charged according to current IQHA fee schedules. Contact IQHA for fees.

12. Types of shows:

a. Single judge open show - 4 classes minimum, 10 classes maximum

b. Single judge show

c. Multi-judge show (two judges)

d. Multi-judge show (three or more judges)

e. Area Championship show

f. Futurity

13. All IQHA-approved shows must have a IQHA judge or judges.

14. Four (4) ROM classes shall be required before a show can be IQHA approved.

C. Forcing Entry and Fee Uniformity

1. No IQHA-approved show may require that an exhibitor must enter or pay fees for a horse in a halter class in order for that horse to be eligible to compete in a performance class, nor may the management require a horse to be entered in a performance class in order that it may be shown at halter. Such entries are made at the option of the exhibitor.

2. At no time may an IQHA-approved show offer reduced entry fees to members of their charters or chapters. All fees will be uniform, whether to

members or non-members of IQHA. Additionally, any requirements imposed upon exhibitors must be applied consistently and equally to all. Failure to adhere to the above will result in possible withholding of future show approvals.

3. All shows approved for IQHA ROM points must be open to all IQHA members in good standing.

D. Showing Unregistered Quarabs and Registered Quarabs without Registration Certificates

1. A fine per animal shall be assessed by the IQHA business office against any show allowing Quarabs to enter without proper original registration papers, complete photocopies of registration papers, or official IQHA Conditional Registration Certificate; plus a fine shall be assessed by the business office against any owner or exhibitor entering a Quarab without proper registration.

2. Any Quarab shown that is unregistered or for which proof of registration has not been furnished will be eliminated, and class placings will be moved by the IQHA Performance Department to reflect the elimination.

E. Balancing Classes Offered

Show Committees should attempt to offer a balanced premium. Example: If a junior horse class is offered, so should a senior class. No discrimination between ages, types, etc. should be made.

F. Specific Classes Offered

Shows may be held that are all youth, Amateur, one division (example – Halter or Western), one type, etc. A Show Committee does not have to offer all divisions.

RULE 34

Limitations

A. At least four point-earning classes, excluding timed events, are required for a show to receive approval.

B. No show conducted by a IQHA charter group whose dates conflict with the World Championship Quarab Show and General Membership Meeting/Convention will be approved.

C. Approval for any show on the weekend after the World Championship Quarab Show will be at the discretion of the Business Office.

D. All applications for shows with names containing the word National, World, or Congress must be approved by the IQHA Executive Committee.

RULE 35

Special Shows

A. Multi-Judge Shows

- 1.** Multi-judge shows are two separate single-judge shows conducted simultaneously in the same ring on one day. Completely separate results forms must be filed for each show.
- 2.** Charters may be limited in the number of multi-judge shows or back-to-back multi-judge shows they may hold in a calendar year, if it is felt such action would be in the best interests of the Association.
- 3.** Exhibitors at multi-judge shows are entering and competing in two separate shows simultaneously, therefore they shall be charged two IQHA office charges (one for each show), and show management shall provide two sets of awards (one for each show).
- 4.** Show management may not combine any qualifying, complimentary, or championship class from one of the shows or judges with another into one event resulting in one award. Each show and class list is to be a separate entity.
- 5.** One show representative may cover both shows, filing two separate reports, of a one-day multi-judge event, or there may be separate show representatives for each show.
- 6.** Timed events based on a point score, such as Jumper, shall be conducted once with both judges submitting separate score cards, or individual goes may be required. Such a decision shall rest with the show management.

B. Area Championships Shows

- 1.** Each area is allowed to hold one Area Championship Show per calendar year which is approved for IQHA points. Area Championship Shows use a single judge whose decisions will receive triple point value. The judge's decision will count as one placing with respect to ROMs; in other words, the championship class win will count only once as a win. Champion of Champions at Halter class is allowed at World and Area Championship Shows. All halter champions except breeding stock will compete for the title of Champion of Champions. This award will be furnished by the IQHA and the winner receives five (5) bonus halter points. Area Championship Shows: The number of points awarded in any class where there are three (3) or less entries shall be a single point (tripled) to the first place Quarab. The number of points awarded in the Champion and Reserve Champion classes where there are less than three (3) entries shall be two (2) points to the Champion and one (1) point to the Reserve Champion (tripled)
- 2.** It is recommended that all charters in an area name one representative to sit on an Area Championship

Board to determine the specifics of their own Area Championship Show. It is suggested that all charters within an area contribute an equal share to a fund from which to host the show. Any show profits/losses would be split equally among those contributing to the fund or be used to continue the fund.

- 3.** The hosting charter must work with the national office in reviewing judges being considered for these shows. Applications for Area Championship Show dates should be submitted no later than November 1 of the year preceding the dates of the show. Application is to be made by the sponsoring board. Areas are not required to host a championship show. If an Area Championship Show is scheduled by November 1 of the previous year, no shows will be approved by IQHA for those dates in the Area or within 350 miles of that location. Exceptions may be made in the case of state and national fairs or shows approved prior to the receipt of the Area Championship Show application. An Area Championship Show may be held over a period of two days and must fall on a Saturday and/or Sunday.
- 4.** IQHA may host Area Championship shows in any area where none is being offered.
- 5.** A IQHA judge may not officiate at multiple Area Championship shows in the same year, unless areas are separated by a minimum of 500 miles.

RULE 36

World Championship Shows

A. IQHA will sanction one show each year to be the World Championship Quarab Show.

B. The Board of Directors shall determine the requirements for and method of choosing a location for the show in a timely manner.

C. The Board of Directors shall determine the show management requirements and responsibilities.

D. There shall be a standard class list consisting of those regular point-earning halter and performance classes that display the Quarab horse in its various capacities. The premium list may include a very limited number of non-point earning classes that promote the breed (e.g., Get of Sire).

E. There shall be a youth activities division as well as an Amateur division, consisting of regular point-earning Western and English youth and Amateur classes, respectively, with one or more age groups.

F. A single class of a performance event (e.g., Working Cow Horse) may receive World Championship status, or an event may be divided into

qualifying classes followed by a World Championship class for the event.

G. Triple points will be awarded for the three-judge average in all classes judged by three judges. In addition, one set of points shall be awarded for each judge's placing. Ribbons or awards for individual judge placings may be given.

H. World Shows may be held outside the U. S. as deemed appropriate by IQHA.

I. The number of points awarded to the winner in any class at the World Show where there are three (3) or less entries shall be a single point (tripled), or, if the class is designated a World Championship Class, two (2) points (tripled) for being named World Champion and one (1) point (tripled) for being named Reserve World Champion. In Halter Championships with less than three (3) entries, the Champion will receive two (2) points tripled and the Reserve Champion will receive one (1) point tripled.

J. A World Show or Quarab Congress will be considered the same as a World Show and all requirements will be consistent.

K. Each World Champion, excluding Breeding Stock, from designated classes (i.e., English Pleasure Saddle Seat, English Pleasure Hunter Seat, or Western Pleasure) will compete for the Champion of Champions title. Same exhibitor is not required. Each will be awarded five (5) points in addition to any other points they may have earned.

L. The Champion of Champions of each seat will compete for the Quarab World Show Supreme Pleasure Champion title. Same exhibitor is not required. The routine for this class is to bring in each Champion of Champions, one at a time, ready for halter, and parade around the ring, one at a time, then line up in the center of the arena. After all horses are lined up in the center, the judge shall inspect for conformation and color. The call judge shall then call in the grooms (no more than 2 per horse) to tack up for pleasure. After a sufficient time has passed, the call judge will excuse the grooms. Each horse shall then be worked on the rail individually, both ways of the arena, according to the specifications of the seat it is showing. After all horses have been worked individually, they shall be worked on the rail collectively, then brought to the center of the arena. After the judges have turned in their cards, the announcer shall read a short resume on each horse.

1. This class is to be judged 75% on rail work, 15% conformation, and 10% manners. Judging will be

made by all six judges, with a drawing to determine the tie breaker, if necessary.

2. The purpose of this class is to select the most outstanding pleasure animal as judged against its own seat/type standards, in direct competition with the Champion of Champions of the other seats. The criteria for judging will be based on the following:

a. Rail work (1-75 pts) - Credit will be given to an animal for the ideal way of going, based on the specifics of the seat being shown;

b. Structural correctness (1-15 pts) - Credit will be given for conformation, correctness and balance;

c. Manner/ Way of Going (1-10 pts) - Credit will be given for a pleasant, manageable attitude & expression.

3. Supreme World Pleasure Champion will be awarded 10 ROM points.

RULE 37

Premium List

A. All classes offered at approved shows must be conducted and judged in accordance with the specifications of the current IQHA Rule Book.

B. The premium list of every approved show must contain the following:

1. Name of the show secretary.

2. Name of the officiating judge.

3. Date, exact location, and starting time of the show.

4. Entry fees and other fees.

5. Disclaimer naming IQHA.

C. Restrictions not clearly printed in the premium list may not be enforced at the time of the show.

RULE 38

Show Management

A. The show manager shall be responsible for the proper organization and conduct of a IQHA-approved show.

B. The show manager shall enforce all rules of the Association from the time entries are admitted to the show grounds until their departure. Each approved show shall have a copy of the current Association Rule Book available for reference at all times during the show.

C. The show manager shall appoint a show representative and supply them with the necessary forms.

D. The show manager shall eliminate a contender who has made an entry of horse, rider, handler, or driver that is ineligible.

E. The show manager shall prevent manual poling with unauthorized poles, or the abuse of a horse anywhere on the grounds.

F. At the earliest possible moment, the show manager shall notify interested exhibitors if a class does not fill and is cancelled or combined. Recommendation: Classes may be combined if there are not enough entries in one of the divisions to earn points. Classes may be split as long as both classes remain a point earning class. Once a Show Committee makes the decision to split, cancel, or combine a class, they may not change that class, even if late entries change the status. It is further recommended that classes should be split or combined first by sex, next by age, and last by type. Refer to Rule 65.B.12.

G. The show manager shall notify the Association of any retirement ceremony held at the show.

H. The show manager shall report in writing to the Association within 60 days of the close of the show the name of any exhibitor whose fees are not negotiable.

I. In the event that any person participating at a show shall commit an offense or violation as described in the rules, the management of the show may, at their discretion, disqualify such person and/or their entries from further participation in their show only. Any such offense shall be reported to the Association for whatever further action is deemed necessary.

J. The show manager shall pay premiums and other indebtedness of the show. Failure to do so subjects the show to a penalty.

K. It will be the duty of the secretary to clearly indicate all ties on show result reports so that points may be awarded properly, and to see that ties are handled in the following manner:

1. A horse tied for other than first place in all jumper classes (both Table I and Table II) shall remain tied, but riders may toss a coin for the ribbons. The ringmaster or show representative may conduct the toss.

2. When points are awarded, each shall receive the number of points offered for the placement in which the tie occurs (i.e., if two horses are tied for fourth and fifth in a full class, each shall receive three points).

RULE 39

Show Representatives

A. General

1. There shall be a show representative at every IQHA-approved show or division.

2. The show representative shall be chosen by show management, and their name shall be posted and/or announced at the show.

3. A show representative must be a current senior member (19 years or older) in good standing with IQHA and not on suspension from any other organization.

4. A show representative may compete in any class at that show for which he/she is eligible.

B. Duties

1. To fill out the form(s) provided by show management and return them to the IQHA business office within fifteen (15) days of completion of the show(s).

2. To report to IQHA on the conduct and performance of the judge(s), ringmaster(s), and show management, and any violations of the rules.

3. To report to IQHA conduct by an exhibitor or any other party on the show grounds which appears not to be in the best interest of the breed, an individual animal, or the Association, and any violations of the rules.

4. To report to the show management any misrepresentation or substitution of entry and report same to IQHA. To report to show management and IQHA any violation of IQHA rules he/she observes during the show(s).

RULE 40

Ringmaster

A. The ringmaster must keep in mind that he has been selected to help the judge and not to advise him. He/she shall carefully refrain from discussing or conferring, or seeming to discuss or confer, with the judge about the animals or exhibitors. A ringmaster shall not take part, or seem to take part, in any of the judging. When not actively engaged in their duties, the ringmaster shall place himself/herself in such a position so as not to interfere with the judging.

B. The ringmaster has charge of the activity in the ring or arena. The judge may request that the ringmaster move and place animals as he advises. The ringmaster shall be familiar with normal horse show procedure, etiquette, and IQHA rules.

C. The ringmaster has the authority, upon request of the officiating judge, to ask an exhibitor to remove

their horse for the safety of other exhibitors and spectators.

D. The ringmaster shall perform any other duties prescribed to him in these rules or any reasonable request from show management.

E. A person may not serve as ringmaster if they or any member of their family or any family owned horses have not yet finished showing at that show.

RULE 41

Judges

A. General

1. Judges must be selected from the current approved list of the International Quarab Horse Association. Upon request the IQHA business office will furnish a list of approved judges to organizations or persons sponsoring shows.

2. All judges are subject to the following conditions:

a. A judge must be a current member in good standing of IQHA to be eligible to judge an IQHA-approved show. All judges will be required to annually renew their IQHA judge's card. There will be an annual judge's card renewal fee.

b. Any person suspended by IQHA for cause will be automatically removed from the list of approved judges, and must reapply for approval in the usual manner.

c. Designation as an approved Quarab Horse Association judge is a privilege only, not a right. This privilege may be bestowed by the Judge Committee of IQHA in accordance with the procedures set up by this committee. Among the qualifications sought are equine expertise, personal character, and interest in the Quarab breed. An individual's conduct as a member, exhibitor, and judge, as well as their ability, are subject to review by the Executive Committee.

d. Removal of an individual from the Association's list of approved judges for any reason, including, but not limited to, suspension from membership, denial of Association privileges, or failure to comply with the Association rules, shall be with no provision for automatic reinstatement. Upon regaining eligibility for approved judging credentials, the individual may apply for reinstatement under the current procedures for admission of a new applicant.

e. If an IQHA carded judge does not attend a IQHA sponsored seminar within a three year period, the card will not be renewed.

f. Rule book tests may be required of judges as deemed appropriate by the judge's committee selectively or as a group at any time for any reason.

3. Contact the IQHA concerning the approval process.

B. Regulations

1. A judge shall not be an exhibitor, show representative, or manager at any show at which he/she is officiating. When shows are held back to back, the judge may not participate in or observe the classes prior to the judging of the show at which he/she is officiating.

2. No Quarab that has been leased from or sold by a judge or their employer within six months prior to the show may be shown before said judge.

3. Unless relationship is terminated within six months prior to the show, a judge shall not adjudicate in a class in which any of their family members, clients, or Quarabs are competing; in which their trainer or trainer's clients or their Quarabs are competing; or in which clients of a member of their family are competing.

4. No individuals nor their Quarabs may show before a judge with whom, within six months prior to the show, they, or their parent, guardian, or instructor has had any financial transactions in connection with instruction or the sale, purchase, lease, board, or training of a horse or pony. (Stud fees and brood mare board excluded.)

5. In a multi-judge show, an exhibitor may show before a judge with whom they have an exhibitor/owner/judge conflict of interest, provided the exhibitor/owner advises the show office of that fact prior to entering the class, and the show office must advise the judge not to place that horse/exhibitor on their card. However, that entry does count as a class entry.

6. A judge shall not discuss with an exhibitor the purchase, sale, or lease of any Quarab during a show at which he/she is officiating.

7. A judge shall not appear on the show grounds prior to thirty minutes before judging is to commence. A judge shall not visit in the horse barns, nor with owners, nor inspect or discuss any Quarab entered in the show before the judging nor shall he/she review the judging program until after the judging has been completed.

8. A judge may not officiate at the same show or for the same sponsoring charter two years in a row.

9. Failure of a judge to attend a show to which he/she is committed or to perform their duties at the show shall constitute cause for disciplinary action except in case of extreme emergency.

10. Judges should be excused or excuse themselves from the immediate area when presentations involving horses being shown are being made in the arena.

11. IQHA Judges and Ring Stewards are prohibited from smoking or chewing tobacco or using cellular phones, beepers or any electronic communication devices in the arena while a class is being judged at

an approved show, except for communication devices used and approved by the show committee.

12. Judge shall not assist in the actual performance of the Quarab/rider on the day of, prior to, or during the class.

13. Judge shall not observe with intent to judge the performance of any Quarabs/riders during practice sessions or warm-up periods prior to the class.

C. Responsibilities

1. No judge shall determine the eligibility for registration of any entry in the ring and shall refrain from making comments regarding such.

2. The decision of a judge constitutes solely their individual preference and not a verdict by the Association.

3. The judge shall have the authority to place each class entrant in the order in which he/she determines entrant places in comparison to other entrants in that class. In no case may a judge place an entrant lower than the actual number of entrants in that class.

4. A judge must order from the ring any unruly Quarab or one whose actions threaten to endanger other exhibitors or their entries. A judge may order from the ring any exhibitor for bad conduct.

5. The judge shall make an individual examination and check the action of all Quarabs brought into a halter class, color classes excepted. This is essential regardless of whether or not the competition indicates that it is necessary. If unsoundness or lameness is evident, this is a cause to eliminate said Quarab.

6. Once a class has been judged and announced, placings are final.

7. The judges will complete an entry tally card verifying the number of entries per class. This includes qualifying halter, color, Amateur, performance, and youth events. Each group in a group class is counted as one entry.

8. Judges at all IQHA ROM-approved shows must select at random one (1) English performance class and one (1) Western performance class in which the bit of each horse in that class will be dropped for inspection in the lineup before awards are presented. Riders must be dismounted prior to bit inspection. One handler is allowed in the ring and it is permissible to put a halter on the animal for safety reasons. When the chosen class is in the ring and the gate is closed, the judges should have it announced that bits will be inspected in that class and handlers with halters should be available at the gate, to enter the ring if necessary.

9. An IQHA judge may not officiate at multiple Area Championship shows in the same year, unless areas are separated by a minimum of 500 miles.

RULE 42

Entries

A. Responsibility

1. Exhibitors are responsible for their own errors and those of their agents in the preparation of entry blanks.

2. Misrepresentation of a Quarab's name, type, registered number, or other information, or substitutions of a horse or pony in the show ring other than the one named in the entry blank for the class in question shall result in the exhibitor's forfeiture of any ribbon, trophy, cash prize, or other award won by such misrepresented or substituted Quarab, and shall render the exhibitor liable for further penalty.

3. Horses and ponies must be entered under their complete IQHA registered name and number and under the name of the owner as shown on the registration papers and the records of the Association or lessee of record.

4. Every entry at an approved show shall constitute an agreement that the person making it, and all persons connected with the Quarab, and the horse entered shall be subject to the Constitution and the Rules of the Association and the local rules of the show.

5. Quarab owners of record who exhibit at IQHA-approved shows must be IQHA members or purchase a membership.

B. Cancellation and Withdrawal of Entries

1. An approved show may adopt its own policy covering the refunding of fees to an exhibitor who cancels their entries prior to or after the show's beginning.

2. If an exhibitor voluntarily removes a Quarab from the ring without the permission of the judge, the exhibitor and all Quarabs of the exhibitor shall be disqualified from all future classes at that show by the Show Committee and shall forfeit all prizes and entry fees for the entire show.

C. Official Entries (shown & judged)

1. To be counted as an official entry in a class, a horse must be in the arena when the gate is closed and must remain in the ring up to the point of the judge excusing it (this is also known as "shown and judged"). An entry may be disqualified by the judge on the basis of going off pattern or course, receiving "no time" in timed competitions, receiving "no score" in roping competitions, or knocking down or refusing obstacles where such action constitutes disqualification. These entries count as official entries.

RULE 43

IQHA Office Charge

A. Every approved show must collect from the entrants, or pay from the proceeds of the show, a per head per judge (show) fee. On back-to-back and multi-judge shows there will be two fees because they are two separate shows. If multi-judge, back-to-back shows are held, a fee from each of the shows will be collected. Futurity shows require separate fees.

B. This fee must be forwarded to the IQHA business office with the show results. No show results will be tabulated until this fee is paid in full.

RULE 44

Show Results

A. The results of any approved show must be completed in their entirety on official forms furnished by the Association listing the first seven horses, unless fewer than that number competed.

B. Results must be filed with the IQHA business office within thirty (30) days after completion of the show. Results must be accompanied by the correct office charge. **Any show not submitting show results within 30 days of the last scheduled show date will be assessed a penalty of \$50 per judge. If results are not postmarked within 45 days, penalty increases to \$200 per judge. Show results and office charge must be submitted to IQHA with the penalty monies. Future show approval is contingent on payment of fees and/or fines/penalties.**

C. Results must indicate all disqualifications-no time, off course, etc.-and halter Champion and Reserve Champion awards.

D. Failure to report complete results within the time limit may result in future approval being denied, censure, or fine by IQHA. Shows which are more than thirty days delinquent in filing their results will be published in The Quarab Horse.

E. A master list on the form provided by IQHA will accompany the show results. This is a complete listing of all Quarabs that entered the show whether or not they placed in a class.

RULE 45

Classification of Shows

Shows are classified according to the actual number of entries in all Quarab classes. This includes qualifying halter (excluding Champion and Reserve halter), color, Amateur, performance, and youth

events. Each group in a group class is counted as one entry.

Class A — shows with 175 or more entries

Class B — shows with 101 through 174 entries

Class C — shows with 51 through 100 entries

Class D — shows with 0 through 50 entries

RULE 46

Ribbons

A. If an approved show offers ribbons, they must be offered through six placings in all classes. At the option of the Show Committee, ribbons and/or awards may be given on average placings in multi-judge shows, but it must be published on the show bill.

B. An approved show located outside the United States may conform to the practice of the country in which it is situated with respect to the color of the ribbons used. At approved shows in the United States the ribbons shall be comprised of the following colors (may be combined with other colors):
Champion — Blue, Red and Yellow, or Purple
Reserve Champion — Red, Yellow and White
First Place — Blue
Second Place — Red
Third Place — Yellow
Fourth Place — White
Fifth Place — Pink
Sixth Place — Green
Area or World Shows may vary from this procedure.

RULE 47

Definitions and General Show Procedures

A. Age

1. Individuals — For horse show purposes the age of an individual on January 1 shall be maintained throughout the entire year. Persons born on January 1 shall assume the greater age of that date.

2. Horses — For horse show purposes any horse shall be considered to be one year old on the first day of January following the actual date of foaling and gain a year in age each consecutive Jan. 1.

B. Riders Exhibiting more than One Entry per Class

1. An exhibitor may show more than one eligible Quarab in individual work performance classes per class specifications.

2. The same Quarab may not be shown by more than one exhibitor nor more than one time in a class, including individual working classes.

C. Eliminations

If there is an elimination, each horse must be ridden in the actual class by the same rider who rode it in the elimination. If a horse is shown in a championship class that is divided into sections, that Quarab must be ridden in the finals by the same rider who showed it in the section. This does not apply to Supreme and/or Champion of Champions classes at the World Championship Show.

D. Splitting of Large Classes

1. When forty (40) or more horses, or riders, or twenty driving entries are entered in a class, that class must be divided into two separate sections and worked, with the top contestants from each section coming back into the ring for final adjudication. No placings, ribbons, or points will be awarded in the sections. Placings, ribbons, and points will be awarded in the finals only.

2. When seventy (70) or more horses or thirty-five (35) driving entries are entered in a class, that class must be divided into three sections and worked, with the top contestants from each section coming back into the ring for final adjudication. Placings, ribbons, and points will be awarded in the finals only.

3. All driving classes shall be divided by the show management when the number of entries exceeds fifteen (15), to be shown in an arena the size of or smaller than 120 feet by 240 feet. Semi-final classes shall not exceed eight (8) entries. In the case of more than eight (8) semi-finals, the above procedure of dividing a driving class shall apply until eight (8) are selected. All semi-finalists shall be ranked until the final class. In the case of multi-judge shows, the split classes shall be run at the discretion of the show management.

RULE 48

General Conduct

A. Any person acting or inciting or permitting any other to act in a manner contrary to the rules of the Association, or in a manner deemed unsportsmanlike, improper, unethical, dishonest, or intemperate, or prejudicial to the best interests of the Association, shall be reported to the Association and subject to disciplinary procedures.

B. An exhibitor may make a request through the ringmaster or other show official to speak with a judge concerning their opinion or decision. Such discussion should take place in the presence of the ringmaster or other show official; however, there shall be no fraternization between an exhibitor and a judge during the show.

RULE 49

Stallions

A. Colts and stallions are prohibited in Youth Activities designated classes.

B. Colts and stallions may be exhibited by persons 14 years of age and over in any class for which they are eligible. However, a Show Committee, if stated in the premium list, may require colt and stallion exhibitors to be 19 years of age and over.

C. For showing purposes the Association considers a colt an unaltered male under the age of four years. An altered male is a gelding, regardless of age.

RULE 50

Combination of Types and Seats

A. All classes are open to all types of Quarabs, with restrictions only to the type of equipment being used in a given class.

B. "Type" refers to the conformation type of the Quarab (Straight/Foundation, Pleasure or Stock) and "seat" refers to the equipment used on the Quarab. To help alleviate confusion for both show management and exhibitors regarding the differences between type and seat in the classes, the following examples are given for reference regarding type of equipment required for specified "seat":

Class Name	Equipment Type
Hunter Under Saddle	Hunter Seat
English Pleasure	Hunter/Saddle Seat
English Pleasure, Hunter Seat	Hunter Seat
Western Pleasure	Stock Seat

C. There shall be no discrimination regarding style of riding any type of horse exhibited in any combined class.

RULE 51

Exhibitor Conduct

A. Attire

1. It is the tradition of the show ring that riders, drivers, and handlers be correctly attired for the class in question, that attendants be neatly dressed, and horses properly presented. Riders in all classes where jumping is required must wear protective headgear except in Trail classes. Recognized attire for each division is required. Protective headgear is recommended in all classes where possible.

2. A Show Committee may at its discretion bar an entry or person from entering the ring if not suitably presented or attired to appear before an audience and must bar riders without protective headgear from classes in which it is required. A judge at their

discretion may penalize an entry whose rider, driver, or handler is not correctly attired for the class in question; however, any exhibitor may wear protective head gear (ASTM/ SEI) in any division or class without penalty from the judge.

B. Numbers

Exhibitors shall display visible number or numbers in all classes. If two numbers are used in a riding class, one shall be on each side of the saddle. Numbers may be displayed on the cart in a driving class as long as the number is visible from the center of the ring, regardless of which way the cart is going. Any exhibitor not displaying a number or displaying a wrong number may be penalized, at the judge's discretion.

RULE 52

Shoeing Regulations

A. General

- 1.** Horses may be shown barefoot or shod in all events.
- 2.** The owner or lessee is responsible for any violations of the shoeing and hoof length regulations, and is subject to penalty in the case of any violation.
- 3.** A horse must conform to its conformation type hoof and shoeing regulations in all classes. Non-conforming entries must be eliminated.
- 4.** Hoof length may be questioned by filing of a protest pursuant to the provisions of Rule 53. If a protest is filed, the horse in question must be measured by a member of show management and the show representative. The results of the measurement will be made available to the Show Committee. If the Quarab is in violation of the rules it shall be disqualified from the balance of the show with all entry fees and awards forfeited.

B. Stock Type

Stock Type horses - The use of shoes other than standard horse shoes is to be discouraged and may be penalized by the judge. Use of wedge pad is permitted. Toe length not to exceed 4-1/2 inches including shoe and pad; weight of shoe not to exceed 12 ounces.

C. Pleasure Type

Pleasure type horses may be shod with a 14 oz. shoe of any type or configuration, except a connecting bar extending below the shoe to both heels. One single pad formed of a continuous material, either synthetic

or leather, that lies flat against both the sole of the foot and shoe (may be thicker at the heel) with no baffles, waffles, rims or projections which may cause sores is permitted. The use of oakum and pine tar, silicone or foam rubber as a packing between hoof and pad for stability is acceptable. The addition of any other foreign object or material is strictly forbidden. The maximum overall hoof length, including the shoe and pad shall be 5".

D. Straight or Foundation Type

Straight/Foundation horses may be shod as either Stock or Pleasure type dependent on their physical conformation – i.e. if they favor pleasure type conformation they should follow the pleasure type recommendations.

RULE 53

Breakage of Equipment

A. In all Western classes, equipment failure or casting of a shoe is an elimination unless entry can continue without interruption. In English classes, except in hunter and jumper classes, in which specific rules prevail, an exhibitor is entitled to request suspension of judging for a period not to exceed seven minutes in aggregate (but no more than two times in a class) in order to repair broken equipment, replace a shoe or rectify a similar accident.

B. The exhibitor must go to the center of the ring for any such emergency, which will constitute a request for time out. Time shall be taken from the moment the exhibitor goes to the center of the ring except in the event of an animal casting a shoe, when time shall not start until the farrier enters the ring or seven minutes has passed. In addition, a maximum of three minutes will be allowed if there is difficulty in finding a lost shoe. It remains the responsibility of the exhibitor to obtain a farrier or qualified person to make necessary repairs. If, at the expiration of the seven minutes the repair has not been made, the contestant may proceed as is without penalty or be disqualified. The ringmaster or judge shall be responsible for timing.

C. If a rider or driver is not involved in a time-out he/she may make minor adjustments that can be performed with the assistance of one attendant and not be charged with a time-out.

RULE 54

Falls

A. A rider is considered to have fallen when they have separated from their mount, which has not fallen, in such a way as to necessitate remounting or vaulting into the saddle.

B. A horse is considered to have fallen when the shoulder and haunch on the same side have touched the ground or an obstacle and the ground.

C. The fall of horse and/or rider shall disqualify the entry, unless otherwise noted in rules.

RULE 55

Cruelty

A. No person on show grounds, including but not limited to, barns, stalls, parking area and show arena, may treat a horse in an inhumane manner. The standard by which conduct or inhumane treatment will be measured is that which a reasonable person, informed and experienced in generally accepted equine training and exhibition procedures, would determine to be cruel, abusive and inhumane.

B. Upon discovery by a show official of inhumane treatment, show management shall immediately report the matter to the Association.

RULE 56

Protest and Controversies - (show-related)

A. Any exhibitor or owner making a protest must be a current member in good standing of IQHA.

B. Any exhibitor or owner making a protest shall lodge such protest with the Show Chairman in writing and signed by the protester within 12 hours of the time of the cause of the protest.

C. The protest must state all alleged rule violations.

D. The protester shall be available to support the protest by personal testimony at the hearing.

E. The protest must be accompanied by a \$200 protest fee in cash, money order, or certified check. If the protest is upheld, the fee will be refunded.

F. The Show Committee shall schedule and hold a hearing within 12 hours of receipt of the complaint or completion of the investigation.

G. Decisions of the Show Committee shall be dated and in writing and may be appealed to the IQHA Executive Committee provided that notice of the appeal is received in the IQHA office within thirty

(30) days from the date of decision of the Show Committee.

H. The appeal must state specifically all alleged rule violations on which the appeal is based.

I. The IQHA Executive Committee will schedule a hearing to consider the appeal pursuant to the hearing procedures outlined in Membership Rule M. The decision of the Executive Committee is final and binding on all parties.

RULE 57

Retirement Ceremony

A. In the event that a retirement ceremony shall be allowed at the request of the owner of a Quarab, said Quarab shall not be permitted to compete at the show. Any Quarab thus officially retired at an approved show shall be barred for life from further competition at approved shows except by special permission of the Executive Committee.

B. Any ceremony announcing an exhibitor's retirement from competition is prohibited. Quarabs may not have a retirement ceremony from individual classes or divisions or competition.

C. Ceremonies at a show will be solely at the discretion of the show management.

RULE 58

Schooling

A. Schooling over any obstacles in the ring or over any part of an outside course at an approved show may be permitted only at a time specified by the Show Committee. All other schooling over obstacles shall be permitted only within clearly identified areas.

B. If an approved show chooses to allow manual poling of hunters and jumpers and the relevant state laws do not prohibit such a practice, it may be done in designated schooling areas only. Single poles of bamboo only (not rattan or any other material) must be used. They may be taped to prevent splitting, but must not be over 2 inches at the large end and must not be inhumane. Exhibitors must furnish their own poles, and no other object may be manually employed.

C. Any violations shall be recorded in the show representative's report and if cruelty or abusive behavior is evident it shall be reviewed by the Executive Committee for such action as may be deemed appropriate to the particular circumstances.

RULE 59

Drugs and Medications

A. General

The rules hereafter are intended to insure the inherent conformation or performance of a horse throughout the competition and to assure that the performance is not altered either deliberately or unintentionally by the influence of drugs and medication.

B. Prohibited Substances

A horse shall not be shown in any class at a show recognized by the IQHA if the Quarab has been administered in any manner any prohibited substance. A prohibited substance is defined as any stimulant, depressant, tranquilizer or local anesthetic which may affect the performance of a horse (stimulants and depressants are defined as medications which stimulate or depress the circulatory, respiratory, central or peripheral nervous system). Also prohibited are any drugs, regardless of how harmless or innocuous they might be, which may interfere with the detection of the aforementioned drugs.

- 1.** The full use of modern therapeutic measures for improvement and protection of the health of the horse, including the nonsteroidal anti-inflammatory drugs is permitted, unless the drug given also may stimulate or depress the circulatory, respiratory, or central or peripheral nervous systems.
- 2.** The use of medicinal preparations and tonics of any kind in which the ingredients and quantitative analysis are not specifically known, is also cautioned against, as the use of such may result in a positive analysis of the specimen taken from the horse.
- 3.** All owners, trainers and exhibitors are accountable for condition of any horse which they enter, or allow to be entered, in any IQHA sponsored or approved event. Such persons are hereafter referred to as "responsible parties". By voluntarily entering a horse in any IQHA approved or sponsored event, the responsible parties are presumed to know all rules and regulations of the Association, including penalty provisions. Based on their accountability for their horse's condition, all responsible parties are subject to disciplinary action any time a prohibited substance is detected at a IQHA approved or sponsored event, regardless of the reason the prohibited substance was administered, and whether or not the responsible parties had actual knowledge of the administration or presence of the prohibited substance.
- 4.** In addition to the "responsible parties" as that term is used in this rule, any person who administers, aids in the administration, causes to be administered, allows to be administered, or conspires in the administration of any prohibited substance shall be

subject to disciplinary action. Such persons are hereafter referred to as "involved parties".

5. It shall be presumed that the sample of urine, saliva, blood or other substance tested by the approved laboratory to which it was sent is the one taken from the horse in question, that its integrity has been preserved, and that all the procedures of the collection and preservation, transfer to the laboratory, analysis of the sample and the report received from the laboratory pertaining to the horse in question are presumed to be accurate and correct reflections of the condition of the horse during the show in which the horse was entered. The burden shall be on the responsible or involved parties to rebut the aforesaid presumption in a hearing conducted by the Association Executive Committee or appointed committee.

6. A request by a IQHA representative or its designee to take a specimen of urine, saliva, blood or other substance for testing shall not be refused by any person. Refusal to comply with such a request shall constitute grounds for immediate disqualification of the horse from further participation at the show, and shows for a period as determined by the IQHA Executive Committee or its appointed appropriate committee and may constitute grounds for disciplinary action against the responsible parties.

7. Cooperation with the veterinarian and/or their agents and/or Association representative shall include, but not be limited to:

- a.** taking the Quarab immediately to the location selected by the appointed veterinarian and/or their agents for testing the horse and presenting it for testing and submitting the registration certificate or a photocopy for the veterinarian's report;
- b.** assisting the veterinarian and/or their agents in procuring the sample promptly, including, but not limited to, removing equipment from the horse, leaving it quietly in the stall avoiding distractions to it. Schooling, lengthy cooling out, bandaging and other delays of this type may be construed as non cooperation;
- c.** polite attitude and actions toward the veterinarian and/or their agents and/or Association representative; and
- d.** failure to cooperate shall be considered a refusal.

8. Horses in competition at recognized shows are subject to examination by a licensed veterinarian or an Association representative who must be approved by the IQHA. The examination may include positive identification, physical, saliva, urine, blood test or other tests or procedures at the discretion of said licensed veterinarian necessary to effectuate the

purposes of this rule. Said veterinarian may examine any or all horses in the class(es) in a show, or any horse entered in any class, whether in competition or not, or any horse scratched or withdrawn (or which simply fails to appear for competition) by any other exhibitor within 24 hours prior to the class for which it has been entered.

9. A horse that has received medication that contains a prohibited substance may be shown if the following requirements have been met and the information requested is furnished in writing to the Show management, as provided below: (Medication Declaration Form)

a. The medication must be therapeutic and necessary for treatment of an illness or injury. (Administration of a prohibited substance for the purpose of shipping, clipping, etc., is not considered therapeutic.)

b. The horse must be withdrawn from competition for a period of not less than 24 hours after the medication is administered, provided the medication is in violation of Drug and Medication Rule;

c. The name of the person administering the drug, and if a prescribed drug, the name of the veterinarian prescribing the drug;

d. Identification of medication — the amount, strength and mode of administration;

e. Date and time of administration;

f. Identification of horse — its name, age, sex, color and entry number;

g. Diagnosis and reason for administration;

h. Statement signed by person administering the medication;

i. Statement filed with the IQHA show management as early as possible and the time of receipt recorded by the show management or their appointed representative;

j. Time of receipt must be immediately recorded upon show office opening or 24 hours prior to the horse being shown. In either event, a medication report must be filed with the show office before the horse enters the ring. Violation may be grounds for disciplinary action.

(1) If the chemical analysis of the sample taken from the horse so treated indicated the presence of a prohibited drug or medication, this shall be prima facie evidence that such has been administered to the horse either internally or externally. However, if the provisions of the drug rule have been complied with, the medication contained in the medication report and any other relevant evidence shall be considered by the Association in determining whether disciplinary action shall be taken against any or all responsible person(s) charged.

(2) Failure to follow all the provisions of the drug rule shall be construed as violation of this rule and may be

grounds for disciplinary action. Such violations must be reported by the show management to the IQHA.

10. Should the chemical analysis on a positive report be received from the laboratory identifying a prohibited substance, or any metabolite or derivative thereof, a hearing shall be provided by the IQHA Executive Committee or its appointed committee. Any responsible or involved parties and/or horses may be subject to any and all, but not limited to, the following penalties:

a. Barred from competition;

b. Forfeit awards, moneys, points or placings, thereby moving up horses placing behind the disqualified horse and possible redistribution of awards, moneys, points or placings;

c. Requested to deliver the horse's registration certificate to be held by the Association for a specified period of time. Although ownership of such horse may, thereafter, be transferred to another party, the transfer of ownership will not dissolve or shorten the terms of suspension;

d. Penalties or fines;

e. Suspension.

11. Federal, state or local laws prevail as applicable.

C. Veterinarian

1. Any licensed veterinarian may officiate in the capacity of horse show veterinarian.

2. Health requirements should be outlined in the catalogs and on the entry blanks and enforced by the show management and veterinarian at facilities where required.

RULE 60

Surgical Alteration

Any surgical or inhumane procedure which could affect a Quarab's performance or alter its natural conformation or appearance is prohibited, except for the sole purpose of protecting the animal. Upon discovery of administration of prohibited surgical procedures, show management shall disqualify the horse and report the matter to the Association. A judge may, at their discretion, penalize a horse for a seemingly "dead" tail that merely dangles between the legs and does not show normal response.

RULE 61

Approved Classes

All classes included in this rule book are ROM pointed except where noted otherwise. Performance classes may be divided into junior and senior classes based on the age of the horse, with junior horses being five years and under and senior horses being six years and older.

RULE 62

Point System

A uniform point system shall be maintained by IQHA with regard to all Quarabs competing for all IQHA awards.

A. Point Scale

1. Points will be awarded only to qualifying Quarabs entered in approved halter, performance, and stock saddle competition events (except where specifically noted in the rules of the class) on the following basis:

Number of official entries	1st	2nd	3rd	4th	5th	6th
8 or more	6	5	4	3	2	1
7	5	4	3	2	1	-
6	4	3	2	1	-	-
5	3	2	1	-	-	-
4	2	1	-	-	-	-
3	1	-	-	-	-	-
2	or fewer	-	-	-	-	-

2. No class of fewer than three entries shall receive points, except: Area Championships, the Quarab World Show and shows given special designation in areas where there have not previously been IQHA shows (as incentive to promote Quarab promotion).

*This special designation exception shall become defunct once established IQHA shows exist in an area. All classes, regardless of number of entries, will be judged.

3. The champion at halter of each sex and type division will be awarded four (4) points if there are at least three (3) Quarabs in the qualifying halter classes in the same sex, age group or conformation type, or if there are at least three (3) entrants competing for Grand Champion and Reserve Champion.

4. The reserve champion at halter of each sex and type division will be awarded three (3) points if there are at least three (3) Quarabs in the qualifying halter classes in the same sex, age group or conformation type, or if there are at least three (3) entrants competing for Grand Champion and Reserve Champion.

B. Open Competition Activities Program

1. IQHA recognizes that Quarabs competing in specialty events may not have the opportunity to earn World points and awards at IQHA approved shows. The Open Competition Activities Program offers recognition of the achievements of these Quarabs in activities outside of IQHA shows.

2. Quarabs residing in areas where there are no IQHA approved shows may also participate in the Open Competition Activities Program. In no case may this program be used instead of participating in IQHA approved shows, if said shows are available.

3. If a specific class (i.e. Jumper) is held (shown and judged) on a limited basis of usually four or fewer times a year in Quarab shows in an exhibitor's area, IQHA will review requests to include open competition points for that event.

4. Open competition points only may be accumulated for horses. No Amateur or Youth points may be earned through this program. No points earned prior to date of IQHA registration will be accepted.

5. IQHA point scale will be used at all times. Those events having special scoring in their IQHA rules will use that scoring when appropriate. IQHA rules will prevail over any outside show, club, or association rules in regard to eligibility or scoring.

6. Points earned through this program will be included in the Quarab's permanent show record and make it eligible for awards under the IQHA Champion, Register of Merit, and Year End Awards programs.

7. Open competition shows may include, but are not limited to, those approved by USDF, USCTA, NCHA, NRCHA, NRHA, FEI, or IAHA (AHA). State and regional association events may also be included.

8. In cutting and roping contests where more than one go-round is held, points shall be awarded from each go-round, not from the average or overall standings at the end of the contest.

9. An IQHA Open Competition Results form must be completed in entirety and submitted to IQHA, along with premium list from the show and applicable per judge show results reporting fee. Only one class and one judge per form. An official copy of points earned from another organization (i.e. USDF, IAHA, etc.) may be submitted for points earned for the current year.

10. IQHA reserves the right to accept or reject open competition points submitted, and to investigate the conditions under which such points may be earned.

11. Combined Driving Is Approved for OCAP points Rule 79.J

C. Point-Earning Events

1. Performance classes titled Championship or Stake receive regular points.

2. Trail classes for Quarabs shown under English equipment and trail classes open to both Western and English equipment may receive ROM points. Points may be withheld from trail classes which restrict exhibitors to either Hunter Seat or Stock Seat equipment unless both classes are offered.

3. Futurity classes (halter or performance) will receive points. Entries in futurity classes are not included as part of the official number of entries in a show. Futurity classes will be approved on an

individual basis as a separate activity if held in conjunction with a show. Futurities require separate approval using a separate show application form. All IQHA rules apply. No rules may be restrictive in nature. Futurity rules must be enclosed with the application. All futurity rules are subject to approval by the IQHA business office. Futurities may be multi-judged. Separate show results and per judge fees are required.

5. All shows approved for IQHA ROM points must be open to all IQHA members in good standing.

D. Non Point-Earning Events

The following classes, divisions, sections, and/or conditions do not receive points toward any IQHA award program:

1. Maiden, novice, limited, or any class whose requirements contain restrictions in regard to previous wins of the Quarab or rider will not receive points in any division except YA and AM Novice.

2. Classes that are considered combined events (**except eventing and combined driving**) such as "Ride and Drive" or "Trail and Jumping".

3. Any class where the specifications or any part thereof as set out in the IQHA Rule Book are changed or altered by the local Show Committee or the judge will not receive points.

4. Classes restricted to ladies or gentlemen for showing, riding, or driving do not receive points in any division except side saddle.

5. Youth or Amateur owner classes that do not conform to the rules of their respective divisions will not receive points.

6. Mixed seat Western and English classes do not receive points or recognition in any division except trail and Amateur Novice classes.

7. Costume, Youth or Amateur color classes, YA Leadline, and YA Walk/ Trot do not receive ROM points (they may receive class specific points).

E. Championship, Legion of Merit, Supreme Champion

All IQHA Championship, Legion of Merit, and Supreme Champion Awards will be separated into individual divisions (Straight, Pleasure, Stock, Amateur and Youth), and a notation made to IQHA ROM records showing the standings in each division.

RULE 63

IQHA Register of Merit Awards Program

A. General

1. Quarabs must be shown at all times under their full registered name and number as shown on their registration certificate, or under the first name choice as shown on the conditional registration certificate

issued by a Sector Director. At no time may a Quarab be shown as "Pending" or "Unnamed". IQHA is not responsible for any loss of points due to a Quarab being shown under any other name or registration number.

2. Points are accumulated from the time a Quarab begins to be shown, regardless of the Quarab's age. All points earned remain so credited if a Quarab is gelded.

3. The current owner(s) as shown in the IQHA records and on the registration certificate, or the lessee if applicable, of a Quarab must be current members in good standing of IQHA for the Quarab to receive any awards. All parties in a joint ownership must be members.

4. The Registration Certificate of any Quarab shall be revoked by the Association if the owner thereof fraudulently advertises, claims, or holds forth that said Quarab is entitled to any IQHA title prior to that title being officially awarded by IQHA.

5. All AM horse/rider combinations shall be referred to as units and must earn points in IQHA ROM-approved Amateur classes.

6. All YA horse/rider combinations shall be referred to as units and must earn points in IQHA ROM-approved Youth activity classes.

7. Competitive riding, endurance riding, eventing, team penning and track racing are exempted from first place award requirements.

8. At such time as any Quarab, AM unit, or YA unit qualifies for any ROM program certificate/award, the owner/AM unit/YA unit as shown in IQHA records will be issued said certificate/award, providing they are current IQHA members.

9. All first place and halter championship requirements must be met from point earning classes.

B. Register of Merit

1. Quarabs/AM units/YA units are advanced to Register of Merit when they have:

a. Open: earned 35 ROM points and one ROM first place win.

b. AM unit: earned 35 ROM points and one ROM first place win.

c. YA unit: earned 35 ROM points and one ROM first place win.

C. Register of Excellence

1. Quarabs/AM units/YA units are advanced to Register of Excellence when they have:

a. Open: earned 175 points and three (3) ROM first place wins.

b. AM unit: earned 175 points and three (3) ROM first place wins.

c. YA unit: earned 175 points and three (3) ROM first place wins.

D. Certificate of Ability

1. Quarabs/AM units/YA units are advanced to Certificate of Ability when they have:

- a. Open: earned a Register of Merit in each of four separate individual performance events.
- b. AM unit: earned a Register of Merit in each of four separate individual performance events.
- c. YA unit: earned a Register of Merit in each of four separate individual performance events.

E. Certificate of Achievement

1. Quarabs/AM units/YA units are advanced to Certificate of Achievement when they have:

- a. Open: earned a Register of Merit in each of six separate individual performance events.
- b. AM unit: earned a Register of Merit in each of six separate individual performance events.
- c. YA unit: earned a Register of Merit in each of six separate individual performance events.

F. Certificate of Superior Ability

1. Quarabs/AM units/YA units are advanced to Certificate of Superior Ability when they have:

- a. Open Horse: earned a Register of Excellence in each of four separate individual performance events.
- b. AM unit: earned a Register of Excellence in each of four separate individual performance events, including showmanship, and equitation.
- c. YA unit: earned a Register of Excellence in each of four separate individual performance events, including showmanship, and equitation.

G. Certificate of Superior Achievement

1. Quarabs/AM units/YA units are advanced to Certificate of Superior Achievement when they have:

- a. Open: earned a Register of Excellence in each of six separate individual performance events.
- b. AM unit: earned a Register of Excellence in each of six separate individual performance events, including showmanship, and equitation.
- c. YA unit: earned a Register of Excellence in each of six separate individual performance events, including showmanship, and equitation.

H. Versatility Award

1. Quarabs/AM units/YA units are advanced to Versatility Award when they have:

- a. Open: earned 65 halter points and one first place award in a regular qualifying class; earned a performance Register of Excellence; earned a Register of Merit in six separate individual performance events, with two being under Western

equipment and two under English, and the remaining being optional.

b. AM unit: earned 65 points and one first place award in either Western or English Showmanship; earned an Amateur Register of Excellence in any event; earned an Amateur Register of Merit in three separate individual performance events (not Showmanship or Equitation), with two being under Western equipment and one under English, or two being under English equipment and one under Western; earned an Amateur Register of Merit in Stock Seat Equitation and Hunter Equitation.

c. YA unit: earned 65 points and one first place award in either Western or English Showmanship; earned a Youth Register of Excellence in any event; earned a Youth Register of Merit in three separate individual performance events (not Showmanship or Equitation), with two being under Western equipment and one under English, or two being under English equipment and one under Western; earned a Youth Register of Merit in Stock Seat Equitation and either Hunter Seat of Saddle Seat Equitation.

I. IQHA Champion

1. In regard to all Quarabs registered by the IQHA, Inc., the title or term "IQHA Champion" is hereby reserved by said Association for its express use and awarded to individual Quarabs/AM units/YA units which meet the requirements set forth in the following section. Quarabs/AM units/YA units are awarded the title "IQHA Champion" when they have:

- a. Open: earned 150 points in competition in IQHA-approved shows (except for Open Competition Activities) provided that:
 - (1) The points have been won under eight or more different judges.
 - (2) At least 65 of the points have been won in point-earning equivalent halter classes or a combination of 55 halter and 10 color points. (Effective Jan. 1, 2005. Not retroactive and by request only.)
 - (3) The halter record include at least three point-earning or equivalent halter class wins, or two point-earning or equivalent halter class wins and a color class point-earning win from at least three different judges as a two year old or older. (Effective Jan. 1, 2005. Not retroactive and by request only.)
 - (4) At least 65 of the points have been won in ROM approved performance classes or racing events.
 - (5) The performance record includes at least three point-earning performance (or racing) wins from at least three different judges, earned as a two-year-old or older (the firsts may be earned in one or more events).
 - (6) The Quarab has earned a minimum of one Register of Merit certificate in performance or racing

events, regardless of the total number of points that he/she has otherwise accumulated.

(7) If the Quarab is a horse, it has earned at least 10 points in a second ROM event in either performance or racing.

b. AM unit: earned 150 points in competition in IQHA-approved shows, provided that:

(1) The points have been won under five or more different judges.

(2) At least 50 of the points have been won in either Western or English Showmanship, but not a combination of both.

(3) At least 65 of the points have been won in performance or equitation events.

(4) The records include at least five point-earning first place awards under at least three different judges.

(5) The AM unit has earned a minimum of three Amateur Register of Merit certificates in any of the approved events, one of which must be in performance or equitation, regardless of the total number of points the AM unit has otherwise accumulated.

c. YA unit: earned 150 points in competition in IQHA-approved shows, provided that:

(1) The points have been won under five or more different judges.

(2) At least 50 of the points have been won in either Western or English Showmanship, but not a combination of both.

(3) At least 65 of the points have been won in performance or equitation events.

(4) The records include at least five point-earning first place awards under at least three different judges.

(5) The YA unit has earned a minimum of three Youth Register of Merit certificates in any of the approved events, one of which must be in performance or equitation, regardless of the total number of points the YA unit has otherwise accumulated.

J. IQHA Legion of Merit

1. In regard to all Quarabs registered by the IQHA, Inc., the title or term "IQHA Legion of Merit" is hereby reserved by said Association for its express use and awarded to individual Quarabs/AM units/YA units which meet the requirements set forth in the following section. Quarabs/AM units/YA units are awarded the title "IQHA Legion of Merit" when they have:

a. Open: earned 650 or more points in competition in IQHA-approved shows (**color classes do not count**) provided that:

(1) The points have been won in twelve or more shows and under forty or more different judges.

(2) At least 185 of the points have been won in point-earning equivalent halter classes.

(3) At least 125 of the halter points have been won in Class A rated shows.

(4) The halter record includes five Championship awards earned at Class A rated shows as a two-year-old or older, all as the same conformation type, and that these were won under at least five different judges.

(5) At least 400 of the points have been won in ROM approved performance or racing events, and at least 20 first place point-earning class wins are included therein, earned as a two-year-old or older.

(6) At least 250 of the performance points have been won in Class A rated shows.

(7) The Quarab has earned a minimum of four Register of Merit certificates in either performance or racing events regardless of the total number of points that he/she has otherwise accumulated.

(8) The Quarab has earned one Register of Excellence award in an approved individual performance or racing event, regardless of the total number of points he/she has otherwise accumulated.

(9) The Quarab must have earned a minimum of 10 points each in at least six different ROM performance or racing events.

(10) At least 10 halter points and 30 performance points must be earned through placings at an Area Championship Show, World Championship Show, Quarab World Show, Congress or Canadian National Exposition.

b. AM unit: earned 650 or more points in competition in IQHA approved shows (except where specifically noted) provided that:

(1) The points have been won in twelve (12) or more shows and under thirty (30) or more different judges.

(2) At least 185 of the points have been won in one of the Showmanship events or a combination of 250 points in English or Western Showmanship.

(3) The Showmanship record includes five first place awards earned at Class A rated shows, and that these were won under at least five different judges.

(4) At least 100 of the Showmanship points have been won in Class A rated shows.

(5) At least 400 of the points have been won in approved performance and/or equitation events, and at least 20 point-earning first place awards have been earned in performance and/or equitation events.

(6) At least 225 of the performance and/or equitation points have been won in Class A rated shows.

(7) The AM unit has earned a minimum of four Amateur Register of Merit certificates in approved individual performance and/or equitation events, regardless of the total number of points the AM unit has otherwise accumulated.

(8) The AM unit has earned one Amateur Register of Excellence award in an approved individual performance or equitation event, regardless of the

total number of points the AM unit has otherwise accumulated.

(9) The AM unit must have earned a minimum of 10 points each in at least six different approved performance and/or equitation events.

(10) At least 10 halter and/or Showmanship points and 30 performance points must be earned at an Area Championship, Quarab World Show, or Congress. c. YA unit: earned 650 or more points in competition in IQHA approved shows (except where specifically noted) provided that:

(1) The points have been won in twelve (12) or more shows and under thirty (30) or more different judges.

(2) At least 185 of the points have been won in one of the Showmanship events or a combination of 250 points in English or Western Showmanship.

(3) The Showmanship record includes five first place awards earned at Class A rated shows, and that these were won under at least five different judges.

(4) At least 100 of the Showmanship points have been won in Class A rated shows.

(5) At least 400 of the points have been won in approved performance and/or equitation events, and at least 20 point-earning first place awards have been earned in performance and/or equitation events.

(6) At least 225 of the performance and/or equitation points have been won in Class A rated shows.

(7) The YA unit has earned a minimum of four Youth Register of Merit certificates in approved individual performance and/or equitation events, regardless of the total number of points the YA unit has otherwise accumulated.

(8) The YA unit has earned one Youth Register of Excellence award in an approved individual performance or equitation event, regardless of the total number of points the YA unit has otherwise accumulated.

(9) The YA unit must have earned a minimum of 10 points each in at least six different approved performance and/or equitation events.

(10) At least 10 halter and/or Showmanship points and 30 performance points must be earned at an Area Championship, Quarab World Show, or Congress.

K. Quarab Supreme Champion

1. Quarabs/AM units/YA units are awarded the title "IQHA Supreme Champion" when they have:

a. Open: earned 1500 points in IQHA-approved shows (**color classes do not count**) provided that:

(1) IQHA Champion and IQHA Legion of Merit awards have been earned.

(2) At least 100 points have been earned in Area Championship shows, National shows, World Championship shows, International Futurities, or Congress.

(3) At least 250 points have been earned in halter.

(4) At least 200 of the halter points have been earned in Class A rated shows as a two-year-old or older.

(5) A minimum of 10 halter championships have been earned as a two-year-old or older under ten different judges, all as the same conformation type.

(6) At least 500 of the performance points have been earned in Class A rated shows.

(7) At least 50 first place awards have been won in performance or racing events at Class A rated shows.

(8) The Quarab has earned two Register of Excellence awards in approved individual performance events, regardless of the total number of points otherwise accumulated.

b. AM unit: earned 1000 points in 20 or more IQHA-approved shows under at least 35 different judges, provided that:

(1) Amateur Champion and Amateur Legion of Merit awards have been earned.

(2) 200 points have been earned in one of the Showmanship events, or a combination of 300 points in Western or English Showmanship, and at least 150 of the Showmanship points earned in Class A rated shows, with 10 point-earning first place awards under at least eight different judges.

(3) 600 points have been earned in equitation or performance events, and at least 400 of the equitation and/or performance points earned in Class A rated shows, with 30 point-earning first place awards under at least eight different judges.

(4) Five Amateur Register of Merit awards have been earned in equitation and/or individual performance events and a minimum of ten points in each of two other equitation and/or performance events.

(5) Two Amateur Register of Excellence awards have been earned, one in equitation and one in an individual performance event.

(6) Ten halter and/or Showmanship points and 30 performance points must be earned at an Area Championship, World Championship, Congress, Canadian National, or World Show.

c. YA unit: earned 1000 points in 20 or more IQHA-approved shows under at least 35 different judges, provided that:

(1) Youth Champion and Youth Legion of Merit awards have been earned.

(2) 200 points have been earned in one of the Showmanship events, or a combination of 300 points in Western or English Showmanship, and at least 150 of the Showmanship points earned in Class A rated shows, with 10 point-earning first place awards under at least eight different judges.

(3) 600 points have been earned in equitation or performance events, and at least 400 of the equitation and/or performance points earned in Class A rated shows, with 30 point-earning first place awards under at least eight different judges.

(4) Five Youth Register of Merit awards have been earned in equitation and/or individual performance events and a minimum of ten points in each of two other equitation and/or performance events.

(5) Two Youth Register of Excellence awards have been earned, one in equitation and one in an individual performance event.

(6) Ten halter and/or Showmanship points and 30 performance points must be earned at an Area Championship, World Championship, Congress or Exposition/World Show.

L. Superior Performance Quarab

While not intended to be above a Supreme Champion, this award is the highest performance award given. It is awarded in two different disciplines, as follows:

1. Horse: earned 8 Register of Excellence awards and 35 point earning first place awards.

2. Amateur Unit: earned 8 Register of Excellence Awards and 35 point earning first place awards, including showmanship, and equitation.

3. YA Unit: earned 8 Register of Excellence Awards and 35 point earning first place awards, including showmanship, and equitation.

RULE 64

IQHA Horse of the Year and AM/YA Top Ten

A. The Association will make annual awards based upon the number of points earned by an individual Quarab or AM or YA competitive unit during that year's competition in each of the approved events in which points are awarded at IQHA-approved shows and any event deemed proper by IQHA.

B. Points will be computed on a yearly basis from December 1 to November 30. Horse of the Year books close December 1 of each year or no later than twenty (20) days after the last IQHA-approved show of that year. Results received by the Association after that date will not be included in the standings.

C. All youth or Amateurs eligible to participate in the IQHA AM or YA Champion and ROM programs are eligible for AM and/or YA yearly high point awards.

D. For an event to receive Horse of the Year status in a specific year it must have been held in at least two (2) separate shows (IQHA-approved or open competition) during that year. For this purpose only, multi-judge shows would be considered one show. If an event does not meet this criterion, it will not appear in the year end standings. The Executive Manager may exempt an event if it is only held at the U.S. or Western Canada World Championship shows.

There is no minimum number of points or point-earners required for Horse of the Year designation.

E. The ten (10) units in each of the two youth age groups - 13 & under; 14 thru 18 earning the highest number of points overall shall constitute the Youth Activities High Point winners. The ten (10) units in each of the two Amateur age groups - 34 & under; 35 & over - earning the highest number of points overall shall constitute the Amateur High Point winners. An appropriate certificate shall be prepared and presented to each youth or Amateur, and the high point winners will be published in The Quarab Quarterly newsletter.

F. The Quarab earning more points during the year than any other of its peers has earned in a given event will be named "Quarab of the Year" in that event. An appropriate certificate shall be prepared and presented to the owner of said Quarab, and the horse's and owner's names will be published in The Quarab Quarterly newsletter.

G. Each of the next nine highest point earning Quarabs for that year in each event will be so designated as "Honorable Mention" and be published in The Quarab Quarterly newsletter.

H. To be eligible for any award in this program, the owner of record, or lessee if applicable, must be a current member of IQHA. AM or YA must be a current member of IQHA.

I. The ten (10) Youth units 18 & under earning the highest number of points in each of the individual YA point earning events during the year will be recognized. The ten (10) Amateur units 19 & over earning the highest number of points in each of the individual AM point earning events during the year will be recognized.

J. YA Horse of the Year, 13 & Under and 14-18. AM Horse of the Year, Jr. & Sr.

K. Tentative Horse of the Year and AM and YA Top Ten placings will be sent to Sector Directors, Charter Presidents, and Newsletter Editors as soon as possible after the results of the last show of the season have been received by the IQHA ROM chairman. It is the responsibility of all persons interested in the Top Ten and Horse of the Year awards to check with these individuals for a copy of the tentative results. Once the Top Ten and Horse of the Year placings have been published in The Quarab Quarterly newsletter, they will be considered official. IQHA reserves the right to correct verifiable errors.

RULE 65

IQHA Youth or Amateur Champion and Register of Merit

A. General

All references to Youth/Quarab or Amateur/Quarab combinations in this section shall be referred to as a unit.

1. All Youth or Amateur exhibitors showing a registered Quarab owned by them or a member of their immediate family as shown in the current records of IQHA are eligible for points and awards in this program. Such ownership must be evidenced by IQHA records at the time the Quarab is shown. IQHA must be notified in writing if more than one surname is used in a family and is not responsible for any loss of points due to different surname or change of surname without prompt notification.
2. Quarabs registered in the name of a ranch, farm or corporation owned by other than immediate family members as defined do not receive youth or Amateur points.
3. For the purpose of the IQHA Youth or Amateur Champion and ROM awards, immediate family shall include father, mother, full or half-sister (husbands of sisters), full or half- brother (wives of brothers), grandparents, aunt, uncle or legal guardian. All youths or Amateurs must be listed, with birth dates, on IQHA membership applications to be eligible for IQHA YA or AM ROM points. IQHA may request proof of relationship if a question arises in regard to same. All IQHA Amateurs must list birthrate on Quarab Amateur Application Form to be eligible to receive IQHA ROM points.
4. To receive any award in this program, the youth or Amateur must be a current member in good standing of IQHA.

B. Substitution

1. There shall be no substitution of one Quarab with or for another in a Youth or Amateur class in a show or in the Youth or Amateur awards program. No performance, showmanship or equitation points can be transferred from one Quarab to another under any circumstances.

C. Competitive Unit

1. A competitive unit shall consist of either one Youth and one IQHA registered Quarab or one Amateur and one IQHA-registered Quarab. Points and awards shall be credited to and earned by the unit.

D. Leases

1. To be eligible for any Amateur or Youth award in the IQHA Register of Merit program with a registered Quarab owned by anyone other than the applicable

Amateur or Youth or a member of their immediate family as defined above (Rule 62.A.3), official IQHA Lease Notification form must be on file with the IQHA office and appropriate filing fee paid for the duration of the lease.

2. A leased Quarab may be shown by both Youth and Amateur exhibitors and may earn both Youth and Amateur ROM points provided the names of each of these exhibitors are shown on IQHA Lease Notification form as recorded lessees of said Quarab.

E. Point System

1. The standard IQHA point system will be used. All Youth or Amateur Quarab shows must have IQHA approval.
2. Triple points will be awarded from World Championship shows for the average placings and 1 set of points for each individual judges placings.
3. YA or AM Halter will count towards IQHA YA or AM awards.
4. Awards apply to YA and AM programs.

RULE 66

Presentation of Horses

A. General Show Rules

Registered horses not typed prior to showing will have to be typed before being exhibited.

1. Refer to the regulations for each type.
2. Supplemental hair in mane and tail is permitted in any division.
3. Jeans are appropriate attire in Stock type halter and Western performance classes.
4. Placing of a horse's feet by hand is permitted.
5. Any tack and/or attire infraction is to be considered as a penalty, not a disqualification, unless specific class rules require a disqualification.
6. No more than eight (8) horses may hand gallop at one time in any class, including disciplined rail classes.
7. In no case may Western and English styles of showing be combined, except in Trail, Side Saddle, AM and YA Novice Walk/Trot, AM and YA Novice Showmanship, and YA Leadline and Walk/Trot. Western and English Showmanship classes, Western and English Pleasure classes, Western and English Equitation classes, etc. may not be combined at any time. No points will be awarded to such combined events.
8. "Type" refers to the conformation type of the Quarab. "Sea t" refers to the equipment used on the Quarab.
9. There shall be no discrimination regarding the style of riding of any type of horse exhibited in mixed seat classes (i.e. trail class).

10. The addition of additional weight to tails or the tying down of tails to restrict movement will be cause for disqualification.

11. In equitation classes, individual patterns are not required if judge includes test in rail work.

12. All riding classes require an appropriate bridle unless specific class rule indicates otherwise.

13. If permissible, whips in halter classes may not exceed 6', including lash; whips in riding classes may not exceed 4', including lash.

14. In all individual work classes, a random draw must be used.

15. Physically Challenged Exhibitor: IQHA will allow any physically challenged exhibitor to enter any class, if the exhibitor can perform the requirements of the class, without jeopardy to other exhibitors or themselves.

B. Stock Type

1. Stock Type horses shall be those that are 51% or greater Quarter Horse or Paint Horse breeding. Stock type horses tend to favor the heavier conformation of Quarter/Paint horses. They tend to be heavier boned with slightly straighter profiled heads.

2. Halter classes-Stock type entries are shown in a halter with lead shank. No assistants are permitted in the ring. Whip or crop is not encouraged. Stock type horses generally stand squarely on all four feet, however, they may stand slightly stretched, especially in classes where all types are shown together.

3. Entries shall be serviceably sound in all halter and performance classes. They may be shown barefoot or shod.

4. Stock type entries may be shown with natural or shortened mane; natural or shortened tail. Braiding or banding is permitted. Roached mane or tail, tail brace, or cap is prohibited

C. Pleasure Type

1. Pleasure Type horses shall be those that are 51% or greater Arabian breeding. Pleasure type horses tend to favor the lighter, more refined conformation of the Arabian. They tend to be finer boned with a more dished profile to the head.

2. Halter classes - Pleasure type entries are shown in a halter with lead shank, show bridle with lead shank, or curb bit with rein. No assistants are permitted in the ring. Whip or crop is optional, but appendages are prohibited. Handlers shall be penalized for excessive use of a whip or actions with a whip that disturb any other entrant. (Penalties may range from a warning to expulsion from the class.)

3. Pleasure type entries shall stand squarely on all four feet or slightly stretched. Front legs must be

perpendicular (at right angles) to the ground and all four feet flat on the ground. Rear legs may be placed squarely under the body or slightly offset (no more than one step). Judge may ask exhibitor to move hind leg(s) under horse for inspection.

4. Entries shall be serviceably sound in all halter and performance classes. They may be shown barefoot or shod.

5. Pleasure type entries may be shown with natural, full, or shortened unset, ungingered tail and full or shortened mane in all classes. Roached mane or tail, tail brace, or cap is prohibited. Braiding is prohibited except in Hunter Seat, Dressage, English Showmanship, parade horse and show horse classes, where Pleasure type entries may be braided according to that individual class specification.

D. Straight (Foundation) Type

1. Straight (Foundation) Type horses are those of 50/50 breeding. They may be first generation horses with a purebred parent of each breed OR they may be second or greater generation Quarab to Quarab breeding. Straight type horses shall display the 'blended' conformation of the Stock breeds and the Arabian. They shall be neither overly refined nor overly stocky, their heads shall show some degree of Arabian influence but shall not be overly dished.

2. Halter classes - Straight type entries are generally shown in a halter with lead shank, show bridle with lead shank, or curb bit with rein. No assistants are permitted in the ring. Whip or crop is optional, but appendages are prohibited. Handlers shall be penalized for excessive use of a whip or actions with a whip that disturb any other entrant. (Penalties may range from a warning to expulsion from the class.)

3. Straight type entries shall stand squarely on all four feet or slightly stretched. Front legs must be perpendicular (at right angles) to the ground and all four feet flat on the ground. Rear legs may be placed squarely under the body or slightly offset (no more than one step). Judge may ask exhibitor to move hind leg(s) under horse for inspection.

3. Entries shall be serviceably sound in all halter and performance classes. They may be shown barefoot or shod.

4. Straight type entries may be shown with natural, full, or shortened unset, ungingered tail and full or shortened mane in all classes. Roached mane or tail, tail brace, or cap is prohibited. Braiding is prohibited except in Hunter Seat, Dressage, English Showmanship, parade horse and show horse classes, where Pleasure type entries may be braided according to that individual class specification.

RULE 67

Breeding Stock Classes

A. General

1. Breeding stock classes may be offered at the option of show management in conjunction with IQHA approved shows.
2. This division is open to purebred mares, stallions, fillies and colts registered with any approved outcross breed listed (Rule 15) **AND** Listed with the IQHA as breeding stock (Listing is free to IQHA members and any animal may be listed on the day of the show).
3. Breeding stock animals will be eligible to earn Registers of Merit and Registers of Excellence in halter classes as outlined in the current rules.
4. Breeding stock animals may not show with registered Quarabs in any classes except group classes (i.e. Get of Sire, Produce of Dam).

B. Halter Classes

1. One class for all ages, sexes, and types is permissible.
2. Halter championship or reserve championship awards are permitted.

C. Performance Classes

1. Western Pleasure and English Pleasure (Hunter and Side Saddle Seats) are the standard performance classes for this division. Other classes may be offered at the option of the Show Committee.
2. Classes shall be judged under regular IQHA rules and will receive IQHA points.

RULE 68

Halter Classes – Horses

A. Judging

The judge should be aware of the fact that not all conformation types are traditionally shown in the same manner. Whereas Stock types usually walk into the ring, Pleasure types are normally brought into the ring at a trot, that gait being an important aspect of their conformation types (Mixed Type classes shall be brought into the ring at a trot).

1. Entries are to be judged on conformation, type, quality, and way of going with attention to the type of conformation and associated expectation in the case of classes not divided by type.
2. Judges may eliminate or severely mark down horses showing in a specific halter section (e.g., Pleasure type) where, in the opinion of the judge, the Quarab is not a correct representative of that conformation type.

3. Blemishes, such as scars, splints, and spavins are to be marked down according to their effect on the soundness of the Quarab. Transmissible weakness and/or unsoundness are to be counted strongly against the horse.

4. Horses are to be shown in hand at a walk and jog or trot.

5. A judge may penalize or disqualify an exhibitor for intentionally dropping the lead during halter or showmanship classes.

6. In weanling classes having suckling entries, it is permissible for the dam to accompany the foal into the arena, but the dam must be placed along the rail.

B. General

1. When a show offers two or more halter sections it is not required to provide the exact same number of halter classes for each section.

Separate halter champion and reserve champion awards should be made in each section. When more than one halter section is provided at a show the following divisions are recommended: Stock type; Straight type; Pleasure type.

2. Quarabs may not cross-enter in breeding stock or halter classes at a show where more than one section is offered.

3. Quarabs may show in one point-earning halter class only per division (open, youth, or amateur division) per show, excluding halter championship and reserve championship judging and ROM-pointed futurity classes.

4. Entering and competing in a halter section or as a type other than the one shown on registration papers shall result in elimination from the class and loss of all awards and points from that class. The Show Committee is responsible for enforcement of this rule. If the show results indicate that any ineligible entrant has placed, the IQHA Performance Department shall have the authority to make the appropriate corrections (i.e., eliminate the ineligible entrant and adjust the placing of the following award winners).

5. Appointments and handling of horses should be consistent with the type of horse being shown. The judge's emphasis is on conformation and type, but circumstances may occur where attire may vary with type being exhibited and discretion should be used by the judge before penalizing the entry. Riding length (below the knee) skirts are acceptable attire in all halter classes if in good taste.

6. In the halter division(s) the championship shall be awarded to one of the horses which has placed first in the qualifying class. After the championship has been awarded the horse which has placed second in the qualifying class to the horse awarded the championship shall compete with the remaining first

place winners for the reserve championship. Should any first place winners in a qualifying class not compete for the championship, the second place horse may be moved up for championship consideration.

7. Only the first and second place Quarabs in a halter class, regardless of conformation type, sex, or age may compete for champion or reserve champion at halter.

8. Halter classes for all sexes and ages of horses must be offered on the show bill whenever halter classes are offered. All ages shall compete for championships.

9. Age groups of the same sex may be combined when there are insufficient entries, with points awarded to the appropriate ribbon winners.

10. Although it is not recommended, sexes may be combined within age groups or by conformation type when there are insufficient entries, with points awarded to the appropriate ribbon winners.

11. When halter classes are divided by conformation type, there must be separate halter champion and reserve awards by type. When two or more halter classes are combined and these classes represent all of the combined Quarabs (example: stallions/geldings or All types), champion and reserve classes connected to these classes must also be combined.

12. It shall be the decision of the Show Committee to split, combine, or cancel classes.

C. Point-Earning Halter Classes

1. Stallions

- a.** Suckling and Weanling Colts
- b.** Yearling Colts
- c.** Two Year Old Stallions.
- d.** Champion and Reserve Champion Junior Stallion
- e.** Three Year Old Stallions
- f.** Four Year Old Stallions
- g.** Five Year Old Stallions
- h.** Six Year Old and Older Stallions
- i.** Champion and Reserve Champion Senior Stallion

2. Mares

- a.** Suckling and Weanling Fillies
- b.** Yearling Fillies
- c.** Two Year Old Mares
- d.** Champion and Reserve Champion Junior Mare
- e.** Three Year Old Mares
- f.** Four Year Old Mares
- g.** Five Year Old Stallions
- h.** Six Year Old and Older Stallions
- i.** Brood mares (Any mare three years of age or older, having produced a registered foal in the current year or immediate previous year.) Entrants in this class are not eligible to compete in any other mare halter class in a show except Champion and Reserve Champion.
- j.** Champion and Reserve Champion Senior Mare

3. Geldings

- a.** Yearling and Under Geldings
 - b.** Two Year Old Geldings
 - c.** Champion and Reserve Champion Junior Gelding
 - d.** Three Year Old Geldings
 - e.** Four Year Old Geldings
 - f.** Five Year Old Geldings
 - g.** Six Year Old and Older Geldings
 - h.** Champion and Reserve Champion Senior Gelding
- #### **4. Breeding Stock Halter Classes (NO Geldings)**
- a.** Junior Arabian Mares (2 & under)
 - b.** Senior Arabian Mares (3 & over)
 - c.** Arabian Broodmares (Any listed Arabian mare three years of age or older, having produced a registered foal in the current year or immediate previous year.) Entrants in this class are not eligible to compete in any other mare halter class in a show except Champion and Reserve Champion.
 - d.** Champion and Reserve Champion Arabian Mare
 - e.** Junior Quarter or Paint Mares (2 & under)
 - f.** Senior Quarter or Paint Mares (3 & over)
 - g.** Quarter or Paint Mares Broodmares (Any listed Quarter or Paint Mares mare three years of age or older, having produced a registered foal in the current year or immediate previous year.) Entrants in this class are not eligible to compete in any other mare halter class in a show except Champion and Reserve Champion.
 - h.** Champion and Reserve Champion Quarter or Paint Mare
 - i.** Junior Arabian Stallions (2 & under)
 - j.** Senior Arabian Stallions (3 & over)
 - k.** Champion and Reserve Champion Arabian Stallion
 - l.** Junior Quarter or Paint Stallions (2 & under)
 - m.** Senior Quarter or Paint Stallions (3 & over)
 - n.** Champion and Reserve Champion Quarter or Paint Stallion

Applies to all divisions except where otherwise noted.

4. Grand and Reserve Champion classes may be grouped by type, sex, or age. When grouped by age, Junior Grand must be two years and under and Senior Grand must be three years and older.

D. Non Point-Earning Halter Classes

1. These halter classes are desirable for all large shows where competition among horse breeders can be stimulated and sufficient entries can be obtained. Registered Quarabs are eligible to participate in these classes.

2. Group classes

a. Produce of Dam — Two produce of any sex and age shall be shown with one handler per horse. Produce need not be owned by the owner of the dam, nor need the produce be owned by one person. Entry must include the name of the dam. More than one set

of entries per dam may be entered in the same class. Emphasis shall be placed upon the reproductive likeness, quality, and conformation. Dams must be registered or listed with the IQHA. Dams are not to be shown.

b. Get of Sire — Two or three get of any sex and age shall be shown, with one handler per horse. Get need not be owned by the owner of the sire, nor need the get shown be owned by one person. Entry must include the name of the sire. More than one set of entries per sire may be entered in the same class. Emphasis shall be placed on reproductive, conformation, and quality. Sires must be registered or listed with the IQHA. Sires are not to be shown.

c. Exhibitor's Quarab Group — Group of three Quarab head of any age or sex all owned by the same exhibitor shall be shown. One handler per horse. Entry is to be made in the name of all three horses. Emphasis shall be placed on uniformity, quality, and conformation.

d. Quarab Mare and Quarab Foal — Mare with foal of the current year shall be shown. Mare and foal do not have to be owned by the same person. One handler per horse. Entry is to be made by the owner of the mare and in the names of both mare and foal. Emphasis shall be placed upon quality and conformation. Mare and foal must be IQHA registered.

E. Color Classes

1. Color classes are judged on the most ideal coloration or markings of an individual Quarab. Ideal markings are defined as a 50-50 distribution of white and color overall on the Quarab for Tobiano or Overo patterns; or for richness of color and/or presence of dun factor in applicable horses. For tobiano and overo horses, it is not necessary for the markings to duplicate themselves on each side of the Quarab.

2. Color classes receive points for Register of Merit and Register of Excellence in Color. Under limited, specific circumstances, up to ten color points and/or one color first place (with its points) may be used toward an IQHA Championship. Color points may **not** be used toward any other open, Amateur, or Youth award. Any points or first place used toward a IQHA Championship may not be used for any color awards.

3. Pattern and Color classes may not be combined (i.e. pinto patterns and other dilutions must be kept separate).

4. Conformation is not considered and the class should not be conducted like a conformation halter class (i.e. entries moved individually).

5. Pattern Class(es)

a. Tobiano Pattern - To be judged 100% on the most ideal markings of the individual Tobiano Quarab.

b. Overo Pattern - To be judged 100% on the most ideal markings of the individual Overo Quarab.

6. Crème Dilute – Palomino and Buckskin horses, judged on richness of color. Palomino horses shall be the color of a newly minted gold coin, mane & tail shall be white. Buckskin horses shall be clear burnished gold with black points (mane, tail, legs). A dorsal stripe is not usually present nor is it required for a bucskin.

7. Dun Factored – Dun dilution results in Grullo, Dun and Red Dun colorations (also included in this group: dunalino and dunskin). Dorsal stripe is required. Other dun factors include:

Face Masking, Cob Webbing, Ear Frames, Barring, Neck Markings, Shoulder Stripe, Rib Barring, Leg Barring and Mottling. White Markings are discouraged in the Dun Factored Class.

8. Champagne Dilution Champagne diluted horses:

F. Longe Line, Yearling or Two Year Old

1. These classes are eligible for Register of Merit and Register of Excellence awards only. In no case will Longe Line points be counted toward any other awards in the IQHA Champion and ROM program.

2. These classes are open only to yearlings and two-year olds, respectively, and may be combined at the discretion of the show committee. Once a two-year old exhibits in a performance class other than a driving class, it will be ineligible to participate in two-year old longe line class.

3. These classes are for all types, and horses may be shown Western or English. It shall be the decision of the show committee to combine or split this class into Western and English or split by types.

4. Equipment - Horses are to be shown in a halter, regular or show type, and suitable in which to be longed. The only attachment allowed to the halter is the longe line, which may not exceed 30 feet in length, with a chain or snap attached to the halter. If a longe line with a chain is used, the chain may NOT be placed over the nose, under the chin, or through the horse's mouth. The longe line must hang free from the halter without touching any part of the horse. It is permissible to use a longe whip.

5. Judging

a. Judges will be outside of the longeing circle. The exhibitor will be allowed one and a half minutes to present their horse. It is suggested, but not mandatory, that the horse walk, jog/trot, and lope/canter, in each direction. The exhibitor may begin work in the direction (counter or clockwise) of their choice. At the end of one and a half minutes, the whistle will be blown and the exhibitor and horse will retire from the longeing area. All horses are to remain in the arena after they have been judged and should stand quietly while other horses are being judged.

b. The horses are judged 70% on their movement and 30% on conformation. Judges should judge the movement of the horse on ability to become a pleasure horse. If a horse's chin or nose area shows any sign of broken skin, rawness, or bleeding, the horse shall be eliminated from the class. If the horse plays on the longe line, it shall not be counted against the horse. The horse should be judged as though a pleasure prospect playing in a field. The judge may penalize a horse for excessive bucking or running off, or displaying attitude uncomplimentary to pleasure horses, such as ear-pinning and tail-wringing.

c. After the longeing competition is completed, the horses shall line up halter fashion and prepare for conformation judging. It is permissible to change lead and Halter for the conformation judging. The judges may not discriminate for or against bulk or height, but rather look for a total picture emphasizing balance and athletic capabilities.

6. Exhibitor

a. An exhibitor may show only one entry per class. The same exhibitor must show the horse in both the longeing and halter phases of the class.

b. Proper Western or English halter class attire is mandatory, and must be consistent with whether the horse is being shown as a Western or English pleasure prospect.

RULE 69

Western Classes

A. General - Refer To General Show Rules

1. Any tack and/or attire infraction is to be considered as a penalty, not a disqualification, unless specific class rules require a disqualification.

2. Entries may be judged for soundness and conformation before entering the arena. Any horse showing evidence of altered tail carriage may be penalized.

3. If bridles are to be removed for bit checks, riders must be unmounted. It is the sole responsibility of the judge to do so. He/she may, however, designate the ringmaster to do so at the out gate.

4. Except for hackamore/snaffle bit classes or junior horses shown with a hackamore or snaffle bit, only one hand may be used on reins, and hands must not be changed except to negotiate an obstacle in a Trail Horse class. When using romal, work hand is to be around reins. No finger between reins is allowed. When using split reins, the index finger only is permitted between reins. Rider may hold romal or end of split reins to keep them from swinging and to adjust the position of the reins provided it is held at least 16 inches from the reining hand.

5. Spurs or romal shall not be used forward of the front cinch. While horse is in motion, rider's hands

shall be clear of saddle except when necessary to use them to prevent a fall. Riders may be disqualified for not following a judge's instructions.

6. Chaps, shotgun chaps, or chinks are optional unless prohibited by specific class rules (i.e. Bareback Equitation).

7. Ties are optional in individual working classes.

8. Jeans are appropriate attire.

9. A junior horse will be allowed to be ridden in performance using a bosal or snaffle bit in any class. A junior horse using a bosal or snaffle bit may be ridden two handed in any class. This includes mixed bit English or Western classes, all divisions (Open, YA, or AM). Refer to snaffle bit classes for specifications on handling or reins and allowable equipment.

10. A junior horse may have been previously exhibited in a shank bit and return to a bosal or snaffle in another class.

11. No more than eight horses may hand gallop at one time in any class, including Disciplined Rail classes.

12. In Western Pleasure, Trail, and Western Riding classes, all gaits should be smooth, relaxed, easy, and efficient. Straight & Pleasure types will move with rounded, medium strides, flexed neck with poll higher than withers, and will display forward reach and flexion of the knees and hocks. Stock types may move with lower strides, poll no lower than level with withers, with less flexion at the knees and hocks. In all cases, the animal should appear balanced and engage his/her hind legs. He/she should move out willingly while remaining balanced and able to stop and stand quietly. Faults would include rough gaits; excessive speed (taking into consideration the difference between types); working excessively on the forehand; inconsistent rhythm and breaking up the clean rhythm of the gait (shuffling or walking with back feet in the jog or four-beat lope).

a. Walk: Free moving but unhurried four beat gait; rhythmical and flat-footed.

b. Jog: Smooth, ground covering two beat gait, with a relaxed back, suspension, and rate that is normal for the conformation type of the entry.

c. Lope: Rhythmical, smooth, unconstrained, with rate that is normal for the conformation type of the entry; elastic and balanced, with three clean beats.

d. Extended gaits: Noticeable difference between the regular and extended gait; no loss of form or balance; excessive speed in any extended gait must be penalized; extensions are accomplished with a lengthening of stride and not just increased speed.

B. Appointments

1. Saddle — Entries shall be shown with a stock saddle, but silver equipment will not count over a good working outfit. Tapaderos are prohibited.

2. The carrying of a lariat or reata, attached to fork of saddle is optional to the exhibitor.
3. Bit / Bridle — There shall be no discrimination against any standard bridle or standard western bit. A standard western bit is defined as having a shank with a maximum length overall of 9-1/2 inches. The mouthpiece will consist of a smooth metal bar or twisted wire with a minimum diameter of 5/16 inch. The port may be no higher than 4 inches from the bottom of the bar to the top of the port. Rollers contained within a legal port are acceptable. The actual roller may extend below the level of the bar. Nothing may be connected or protruding below the bar. Copper wrapped bits are acceptable. Any bit with sharp edges will be disqualified. Roping bits with both reins connected to a single rein at the center of the cross bar are prohibited. Reins must be attached to each shank. The judge may prohibit the use of any equipment he/she considers severe or inhumane. Curb chains may be used, but must be at least 1/2 inch in width and lie flat against the jaws of the horse. Horses shall not be shown with artificial appliances that would tend to alter their performance. No wire or other metal or rawhide may be used in conjunction with, or as part of, the flat leather chin strap, which must be at least 1/2 inch in width. Round rolled, braided, or rawhide curb straps are prohibited. Refer to Section C below for snaffle bit regulations.
4. Hackamore bits, mechanical hackamore, cavesson-type nosebands, martingales, tie-downs, and choke ropes are prohibited. See other rules for exceptions.
5. Boots or bandages are prohibited in western pleasure and trail horse classes. The use of shin and/or bell boots on the front legs and standard sliding or rundown boots on rear fetlocks is optional in individual working classes unless otherwise noted. In the event of injury the judge may permit a protective bandage.
6. Junior horses — Horses five years and under may be shown in a standard rawhide or leather braided hackamore (consisting of bosal, headstall, and reins) or ring snaffle in any class. Bosal must be a maximum of 3/4 inch in diameter. No **iron** is permitted under the jaws regardless of how padded or taped on the bosal portion of the hackamore. In no case does this refer to a so-called ‘mechanical hackamore’. Absolutely no metal under the jaw or as part of the noseband is permitted in conjunction with the bosal.
7. Entries must be penalized for incomplete appointments, but not necessarily disqualified. A judge does not have the authority to add to or remove any of the standard equipment as specified.
8. Dress — Exhibitors shall wear western hat, long-sleeved shirt with collar, jeans or pants, and boots. Gloves and spurs are optional.

9. Chaps, shotgun chaps, or chinks are optional unless prohibited by specific class rules (i.e. Bareback Equitation).

C. Snaffle Bit Classes

Snaffle bit rules apply to all types of horses when using snaffle bits.

1. Horses are not restricted as to type of equipment used while ridden in other classes.
 2. A junior horse, in snaffle bit classes, is to be ridden with two hands
 3. Equipment for horses using snaffles or bosals in any class.
 - a. Horses are to be shown in standard, plain, or silver head stalls (browband, shaped ear, or split ear). Smooth snaffle bit with broken mouth-piece (conventional O-ring, egg butt, or D-ring) with ring no larger than 4 inches and no smaller than 2 inches. (One inch in from cheek, must be a minimum 5/16 inch diameter with a gradual decrease to the center of the snaffle. Optional loose curb strap (leather or nylon only). No twisted wire or copper-wrapped bits allowed. No twists or rolls in mouthpiece are allowed.
 - b. Reins are to be attached above the curb strap.
 - c. Standard, leather or woven, split reins are mandatory.
 - d. Martingales, nose bands, or tie downs are prohibited.
 - e. A braided rawhide or leather bosal may be used in lieu of a snaffle bit, no larger than 3/4 inch diameter at the cheek; must be a minimum of a one-finger space (approximately 3/4 inch) between the bosal and nose; absolutely no metal under the jaw or in the noseband in connection with the bosal. The bosal should be properly fitted relative to the horse’s size and conformation.
 4. If classes are held exclusively for hackamore or snaffle bit junior horses, two hands must be used. See page 64 for proper handling of reins.
 5. A bosal may have a mecate (tie or lead rope).
 6. Classes limited to snaffle bit horses ages five and under may be held with ROM approval.
- Refer to page [] for bit and hands illustration.**

D. Western Pleasure

1. Horses to be shown at a walk, jog, and lope, both ways of the ring, on a reasonably loose rein, without undue restraint. Judge may ask for an extended walk, jog, and/or lope. Special emphasis should be placed on the walk. All horses being considered for an award are required to back in a straight line. The ideal pleasure horse should carry its head in a position that is normal for its type and no lower than level. Reasonably loose reins with light contact should be maintained at all times. Carrying the head in such a position that the point of the ears is lower than the

withers, being flexed behind the vertical and moving exceptionally slowly at any gait are to be considered major faults. Horses that are considered by the judge as appearing lethargic, sullen, drawn, emaciated, or overly tired should not be considered for a placing. The western pleasure horse should be a pleasure to ride and a free, natural mover.

2. All horses chosen for a workout must be worked both ways of the ring, at any gait requested by the judge.

3. Horses to be judged on performance, manners, conformation, suitability and appointments.

4. If a horse and a rider are traveling properly in all three gaits, they should not be penalized for passing another horse.

E. Trail — English or Western

1. Trail horses are required to work over and through obstacles. Failure to attempt to negotiate obstacles in prescribed order will result in disqualification.

2. Tests which may be required are negotiating the gate, carrying objects from one part of the arena to another, riding through water, over logs or simulated brush, riding down into and up out of a ditch without lunging or jumping, crossing a bridge, backing through obstacles, sidepassing, mounting and dismounting from either side (note: Dismounted maneuvers are extremely time-consuming and often triple the length of time necessary to get a horse over the course, particularly in classes with a large number of entries), and performing over any reasonable conditions encountered along the trail. Obstacles such as fire extinguishers, any objects floating in water, any live animals or unsafe element or any obstacle that performs unequally for each horse are to be avoided. These are of no benefit and actually increase the burden on those who must judge.

3. The course is to include a minimum of six obstacles and a maximum of eight obstacles. Care in preparing the course should be exercised to prevent direct advantage to either a small or large horse. Ingenuity in adapting and combining various obstacles will lend itself to creating courses pleasing to both exhibitors and judges. To include a jog and a lope of suitable duration to determine the way of going management is encouraged to design courses that can be negotiated in 90 seconds.

4. Horses are to be penalized but not disqualified for any unnecessary delay while approaching an obstacle. Judges are encouraged to advance on to the next obstacle any horse taking excessive time at an obstacle. A time limit may not be placed on the course as a whole or individual obstacles. While the horse is on course, the rider's hands shall be clear of the horse to avoid cueing.

5. Entries will be evaluated on responsiveness, willingness, and general attitude. Entries should demonstrate the control, flexibility, and calmness (sensibility) of the ideal trail horse.

6. Horses are to be shown over and through obstacles at a walk, jog, and lope on a reasonably loose rein without undue restraint.

7. Horses are to be judged on performance and way of going with emphasis on manners, suitability, and appointments.

8. Trail course must be posted one hour prior to class at the regular show.

9. Off course is a disqualification and is defined as:

- a. taking an obstacle in the wrong direction.
- b. negotiating an obstacle from the wrong side.
- c. skipping an obstacle unless directed by the judge.
- d. negotiating obstacles in wrong sequence.
- e. not following the correct line of travel.

10. Mandatory obstacle dimensions Trail and

Trail-in-Hand Classes:

	In-Hand	Riding
a. Walk overs Minimum width	20-24"	20-24"
Multiple pole Minimum width	20"	20"
Single poles Maximum height	8"	12"
Multiple poles Maximum height	6"	10"
No rolling poles		
b. Jog overs Minimum	30"	36"
Raised Maximum height	6"	10"
c. Jog arounds or serpentine 6' min 8' max		
d. Back thrus or arounds		
On ground Minimum width	24"	28"
Elevated Minimum width	28"	30"
Barrels Minimum width	30"	32"
e. Side pass Minimum width	24"	24"
Raised Minimum height	24"	24"
f. Circle turn around Minimum	22"	30"

g. Cavaletti

Jog overs 3' to 3'6" apart (space is measured between poles)

Lope overs 6' to 7' apart (7' is preferable for most horses)

Jog overs Raised Maximum heights 10"

Lope overs Raised Maximum heights 10"

h. Jumps

Mounted Maximum height: 24"

Lead over Maximum height: 18"

Maximum height: 12" Horse & Handler

Mounted Minimum width between jump standards 4'

Combinations 12' for one stride 6' for no stride

Lead over Minimum width between jump standards 3'

Lead over Multiple jumps Maximum height 12"

Box jumps and L-jumps Poles must be at least 12' long

i. Tires

If there is a space between tires, it should be equal to the

outside diameter of the tire.

j. Serpentine

Jog arounds - Pylons 6' minimum to 8' maximum apart (base to base)

Guardrails 3' to either side of pylons.

Walk arounds - Pylons 3' apart (base to base) minimum.

Guardrails 6' to 8' to either side of the pylons.

If tall standards are used, dimensions may be looser.

k. Gate

Approximately 60" high with latch available at that height.

l. Any other maneuvers

Figure horse's wheel base at 5' front hooves to back hooves.

11. Obstacles must be measured with accurate measuring device {i.e. measuring tape, ruler, or yard stick}, and measurements to be taken from the inside width of poles or obstacles.

F. Yearling & Two-Year Trail-In-Hand

1. General

a. Horse to be shown in halter with appropriate lead. (Halters with bits are permissible for 2 yr olds.) Chain on the lead is permitted under the chin of the horse. Handler must maneuver horse using leadline of halter only. Horse may not be touched by the handler unless the judge or course designer instructs or if sidepassing is required. Whips or crops are not allowed. Handler may be requested to lead from either side. One handler may show more than one entry in this class. Tying up of long tails is permissible in this class.

b. In Trail-in-Hand, baiting to encourage an animal to perform one of the obstacles is not allowed. Any baiting in such class shall result in a disqualification.

2. Course

a. Trail horses in hand are required to work over, under and through obstacles. Failure to attempt to negotiate obstacles in prescribed order will result in disqualification.

b. Obstacles should simulate conditions normally encountered at the ranch, shows, open trails, or parades. Unnatural or "horror" obstacles should be avoided.

c. Course to include a minimum of six and maximum of ten obstacles, with a minimum of one obstacle from three different categories listed below.

d. Course designer must keep in mind both the size of the horses as well as their safety. Care in preparing the course should be exercised to prevent direct advantage to either a small or large horse. Ingenuity in adapting and combining various obstacles will lend itself to courses pleasing to both exhibitors and judges. To include a walk and jog of suitable duration

to determine the way of going. Lope or canter shall not be used in in-hand classes.

e. Speed is not to be used to determine placing, though excessive delay while approaching obstacle is to be penalized. Judges are encouraged to advance on to next obstacle any horse taking excessive time at an obstacle. A time limit may not be placed on the course as a whole or individual obstacles.

f. Entries will be evaluated on responsiveness, willingness, and general attitude. Entries should demonstrate the control, calmness (and sensible attitude) of the ideal trail horse.

g. All poles used on course raised off the ground shall be made of PVC pipe with a minimum diameter of 2".

3. Categories of suggested obstacles

a. Overs:

- (1) Bridge.
- (2) Tarp.
- (3) Water.
- (4) Single horizontal pole with maximum height of 8".
- (5) Deflated inner tubes (May choose to step on or n).
- (6) Multiple walk-over poles with 6" maximum individual heights.

b. Unders:

- (1) Clothesline with clothes hanging up.
- (2) Light pole suspended at a minimum height of four inches above the tallest horse's back.
- (3) Canopy.

c. Back throughs:

- (1) Backing through an L.
- (2) Back around a barrel, a pair of barrels or other visible obstacle.

d. Serpentine:

Proceed at requested gait, through a pattern such as in and about of a series of poles or pylons. Walk or Trot may be requested.

e. Jumps:

- (1) Individual jump not exceeding 18" if horse only is to go over. Handler goes around.
- (2) Multiple jumps should not exceed 12" in height and should be 3' to 4' apart.
- (3) If both horse and handler are required to go over the single jump, it should not exceed 12" in height. Handler is not required to jump.
- (4) Ground poles are recommended for all jumps.

f. Daily chores:

- (1) Negotiate a gate.
- (2) Handler to carry an object from one part of the arena to another.
- (3) Lay a saddle pad, blanket or sheet on horse's back.
- (4) Brush horse's tail.
- (5) Go through motions of measuring horse's height at the back with a yard stick or tape measurer.
- (6) Load in trailer or chute.

g. Control obstacles:

- (1) Ground tie and walk around.
- (2) Stand horse in circle and turn on forehand and/or hindquarters.
- (3) Side pass either or both directions.

4. Off course

Off course is a disqualification and is defined as:

- a. taking an obstacle in the wrong direction.
- b. negotiating an obstacle from the wrong side.
- c. skipping an obstacle unless directed by the judge.
- d. negotiating obstacles in wrong sequence.
- e. not following the correct line of travel.

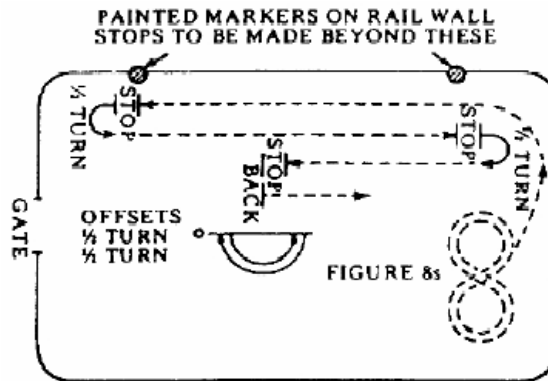

G. Stock Horse

1. Horses shall be worked individually. After executing a walk, jog, and lope, rider shall start their workout with a figure eight, executed at a lope once or twice and of sufficient size to avoid short, choppy turns. One figure eight demonstrates two changes of leads and is completed by closing up the last circle and stopping in the center of the eight. Two figure eights demonstrates four changes and are completed in the same manner. Failure of the horse to change both front and hind leads shall be faulted. The smoother and more even the gait, the more credit to the horse. Entry shall then go to the end of the arena, turn, and run full-length of the arena to a straight, sliding stop; turn away from the rail and run to the other end of the arena and make a straight, sliding stop; turn away from the rail and run to the center of the arena and make a straight sliding stop. After allowing the horse to gather itself, the horse shall be backed in exactly the opposite direction in a straight line for 10 to 15 feet. The horse shall then be brought forward, stopped, and with weight on the hind quarters and with legs in one position, shall make a half turn once each way. Riders may also be asked to execute one and one half (1 1/2) turns on ends and full turns each way in the center.

2. The foregoing is set up as a guide, but the judge may deviate from this procedure (roll backs are prohibited, however). A judge may also deviate from the standard pattern if necessary in placing their class. When complementary classes (e.g., Jr. Horse and Sr. Horse) are offered, the same reining test must be used in each.

3. Horses are to be shown at a walk, jog, and lope without undue restraint, must lope a figure eight, run at speed, and stop and turn easily.

4. Horses are to be judged on rein, manners, conformation, and appointments.

5. Horses going off pattern will be disqualified.

H. Reining

1. Each contestant will perform the required pattern individually and separately. To rein a horse is not only to guide it, but also to control its every movement. The best reined horse should be willfully guided or controlled with little or no apparent resistance, and dictated to completely.

a. Any movement on its own must be considered a lack of control.

b. All deviations from the exact written pattern must be considered a lack of or temporary loss of control and therefore faulted according to severity of deviation.

c. Credit will be given for smoothness, finesse, attitude, quickness, and authority in performing the various maneuvers while using controlled speed.

2. In an approved Reining class, any one (1) of the five (5) approved IQHA Reining patterns may be used.

a. One (1) of these five (5) patterns is to be selected by the judge of the class and used by all contestants in the class.

b. Barrels and chairs may not be used as markers in the pattern.

3. Scoring will be on the basis of zero (0) to infinity, with seventy (70) denoting an average performance. The individual maneuvers are scored in 1/2 point increments, from a low of -1 1/2 to a high of +1 1/2, with a score of 0 denoting a maneuver that is correct with no degree of difficulty.

a. The following will result in no score (DQ):

(1) Infraction of any state or federal law which exists pertaining to the exhibition, care, and custody of horses within the state or country where a IQHA reining event is being held.

(2) Abuse of an animal in the show arena and/or evidence that an act of abuse has occurred prior to or during the exhibition of a horse/pony in competition.

(3) Use of illegal equipment.

(4) Use of any attachment which alters the movement of or circulation to the tail.

- (5) Failure to dismount and/or present horse and equipment to the appropriate judge for inspection.
- (6) Disrespect or misconduct by the exhibitor.
- (7) The judge(s) may excuse a horse at any time while in the arena for unsafe conditions or improper exhibition pertaining to both the horse and/or rider.
- b.** Excess rein may be straightened at any place a horse is allowed to be completely stopped during a pattern. When using a romal, no fingers between the reins are allowed. The free hand may be used to hold the romal, provided it is held at least 16 inches from the reining hand and in a relaxed position. Use of the free hand while holding the romal to alter the tension or length of the reins from the bridle to the reining hand is considered to be the use of two hands, and a score of 0 will be applied, with the exception of any place that a horse is allowed to be stopped in the pattern
- c.** The following will result in a score of 0 (DQ):
 - (1) Use of more than index or first finger between reins.
 - (2) Use of two hands (Exception: In Snaffle Bit or Hackamore classes designated for two hands.) or changing hands.
 - (3) Use of romal other than as outlined in number 8 above.
 - (4) Failure to complete pattern as written.
 - (5) Performing the maneuvers other than in specified order.
 - (6) The inclusion or maneuvers not specified, including, but not limited to:
 - (a) backing more than 2 strides;
 - (b) turning more than 90 degrees (Exception: A complete stop in the first quarter of a circle after a canter departure is not to be considered an inclusion of maneuver; a 2 point break of gait penalty will apply.)
 - (7) Equipment failure that delays completion of pattern.
 - (8) Balking or refusal of command where pattern is delayed.
 - (9) Running away or failing to guide where it becomes impossible to discern whether the entry is on pattern.
 - (10) Jogging in excess of 1/2 circle or 1/2 the length of the arena.
 - (11) Overspins of more than 1/4 turn.
 - (12) Fall to the ground by horse or rider.

Note: Neither a no score nor a 0 are eligible to place in a go round or a class.

- c.** The following will result in a penalty of five (5) points:
 - (1) Spurring in front of cinch.
 - (2) Use of either hand to instill fear or praise.
 - (3) Holding saddle with either hand.

- (4) Blatant disobedience including kicking, biting, bucking, rearing, and striking.
- d.** The following will result in a penalty of two (2) points:
 - (1) Break of gait.
 - (2) Freezing up in spins or rollbacks.
 - (3) On walk in patterns, failure to stop or walk before executing a canter departure.
 - (4) On run in patterns, failure to be in a canter prior to reaching the first marker.
 - (5) If a horse does not completely pass the specified marker before initiating a stop position.
- e.** Starting or performing circles or figure eights out of lead will be judged as follows:
 - (1) Each time a horse is out of lead, a judge is required to penalize by 1 point. The penalty for being out of lead is accumulative and the judge will add 1 penalty point for each 1/4 of the circumference of a circle or any part thereof that a horse is out of lead.
 - (2) A judge is required to penalize a horse 1/2 point for a delayed change of lead by 1 stride.
- f.** Deduct 1/2 point for starting circle at a jog or exiting rollback at a jog up to 2 strides. Jogging beyond 2 strides but less than 1/2 circle or half the length the arena, deduct 2 points.
- g.** Deduct 1/2 point for over or under spinning up to 1/8 of a turn; deduct one (1) point for over or under spinning up to 1/4 of a turn.
- h.** In patterns requiring a run-around, failure to be on the correct lead when rounding the end of the arena will be penalized as follows:
 - (1) For 1/2 the turn or less, 1 point.
 - (2) For more than 1/2 the turn, 2 points.
- i.** There will be a 1/2 point penalty for failure to remain a minimum of 20 feet from wall or fence when approaching a stop or rollback.
- j.** All riders must dismount and drop the bridle immediately after the performance. The bridle must be checked by the designated judge in the arena or in close proximity to the arena. Failure to comply will result in a no score.
- k.** Judge(s) shall be the sole person(s) responsible to determine if a rider has completed the pattern as written.

**Reining Pattern #1
(adopted by the color breed council)**

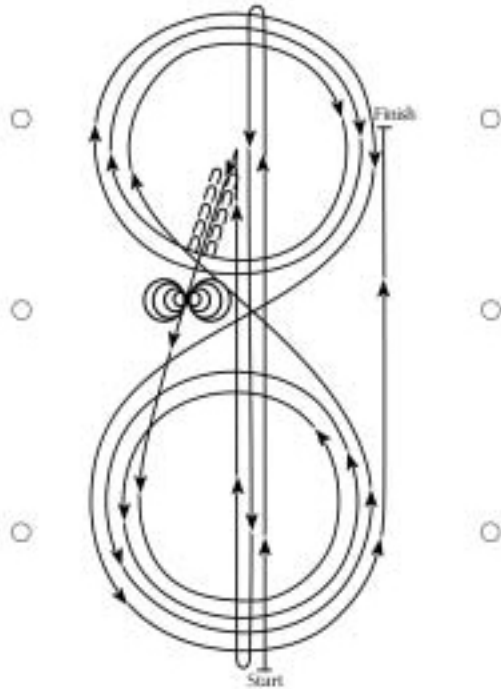

1. Run at speed to the far end of the arena, past end marker, and do a left rollback—no hesitation.
2. Run to opposite end of the arena, past end marker, and do a right rollback — no hesitation.
3. Run past center of the arena. Do a sliding stop. Back straight, to the center of the arena. Hesitate.
4. In the center of the arena, complete four spins to the right.
5. Complete four and a quarter (4-1/4) spins to the left, so that horse is facing left wall or fence. Hesitate.
6. Beginning on the left lead, complete three circles to the left. The first circle, large and fast; the second circle, small and slow; the third circle, large and fast.
7. Change leads at the center of the arena.
8. Complete three circles to the right. The first circle, large and fast; the second circle, small and slow; the third circle, large and fast.
9. Change leads at the center of the arena, and begin a large fast circle to the left. Do not close this circle. Run straight down the side of the arena, past center marker, and do a sliding stop, at least 20 feet from wall or fence.
10. Hesitate to demonstrate the completion of the pattern.
11. Rider must drop bridle to the judge.

Reining Pattern #2
(adopted by the color breed council)

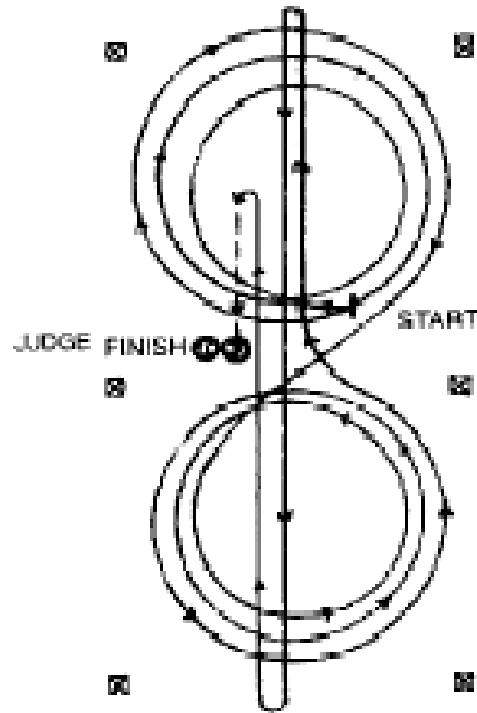

1. Beginning at the center of the arena, complete one small slow circle to the right, and then two large fast circles to the right.
2. Change leads at the center of the arena.
3. Complete three circles to the left. The first circle, small and slow; the next two circles, large and fast.
4. Change leads at the center of the arena.
5. Run to the far end of the arena, past end marker, and do a left rollback — no hesitation.
6. Run to opposite end of arena, past end marker, and do a right rollback — no hesitation.
7. Run past center of arena and do a sliding stop. Back, straight to the center of the arena. Hesitate.
8. Complete four spins to the right.
9. Complete four spins to the left.
10. Hesitate to demonstrate the completion of the pattern.
11. Rider must drop bridle to the judge.

Reining Pattern #3
(adopted by the color breed council)

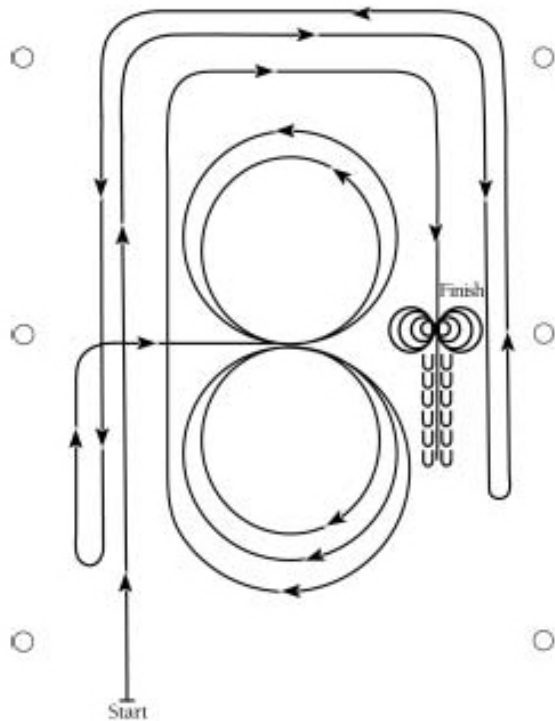

1. Begin approximately 20 feet from the left wall or fence.
2. Lope straight down the side of the arena, staying 20 feet from the fence. Circle the top end of the arena and run straight down opposite side of arena, past center marker, and do a left rollback*.
3. Continue straight down the side, at least 20 feet from the wall or fence, and back around top of arena (horse to be on left lead at this point), running straight down the other side of arena, at least 20 feet from the wall, past center marker, and do a right rollback*.
4. Continue up the left side of arena to center marker, and at center marker horse should be on right lead. Continue to center of arena on right lead.
5. Complete two circles to the right. The first circle, small and slow; the second, large and fast. Change leads at the center of the arena.
6. Complete two circles to the left. The first circle, small and slow; the second, large and fast. Change leads at the center of the arena.
7. Begin a large fast circle to the right. Do not close this circle.
8. Continue straight down the side, at least 20 feet from the wall or fence. Circle the end of the arena, and run straight down the opposite side of the arena, past center marker, and do a sliding stop, at least 20 feet from the wall. Back up at least 10 feet. Hesitate.
9. Complete four spins to the right and four spins to the left.
10. Hesitate to demonstrate the completion of the pattern.
11. Rider must drop bridle to the judge.

*Horse may come out of rollback on either lead; however, they should be on correct lead when rounding the end of the arena.

Reining Pattern #4
(Recommended for YA and AM Reining)

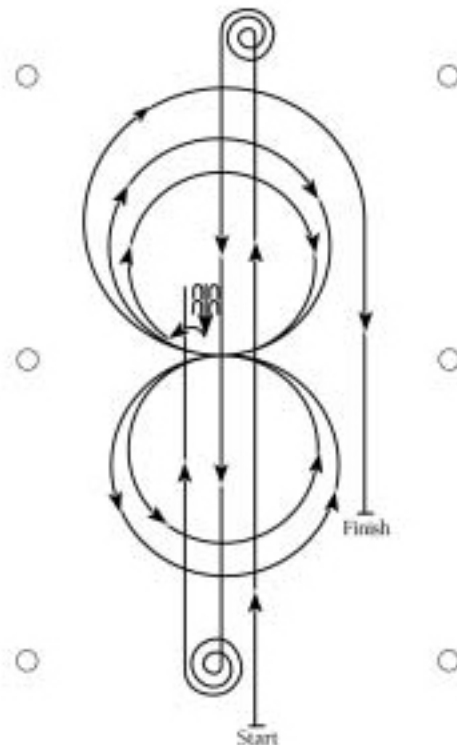

- The arena or plot should be approximately 50 x 100 feet in size. The judge shall indicate with markers on arena fence or wall the length of the pattern. Markers within the area of the pattern will not be used.
- Ride pattern as follows:
1. Run to the far end of the arena. Stop, and do 2-1/2 spins to the left — no hesitation.
 2. Run to the opposite end of the arena. Stop, and do 2-1/2 spins to the right — no hesitation.
 3. Run past center of arena. Do a sliding stop - no hesitation. Back over slide tracks to center — hesitate.
 4. Make a 1/4 pivot to the left to face left wall - hesitate.
 5. Begin on right lead and make two circles to the right. The first circle, small and slow; the second, large and fast. Change leads at center of arena.
 6. Make two circles to the left. The first circle, small and slow; the second, large and fast. Change leads at the center of the arena.
 7. Begin a large fast circle to the right. Do not close this circle, but run straight down the side, past the center, and do a sliding stop, at least 20 feet from wall or fence.

8. Walk to the judge and stop for inspection until dismissed.
9. The bridle may be dropped, at the judge's discretion.

**Reining Pattern #5
(Recommended for YA and AM Reining)**

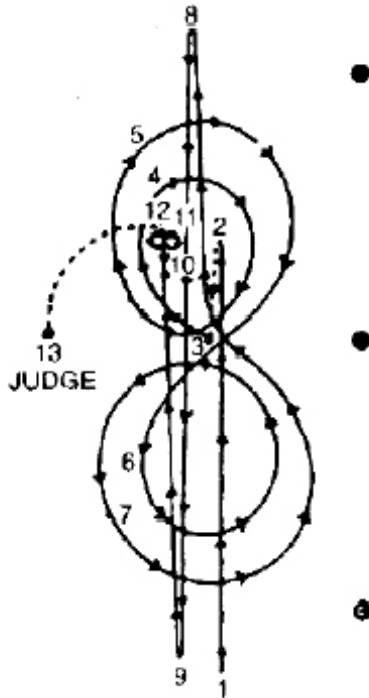

The arena or plot should be approximately 50 x 150 feet in size. The judge shall indicate with markers on arena fence or wall the length of the pattern. Markers within the area of the pattern will not be used.

Ride pattern as follows:

1. Run with speed past center marker.
2. Stop and back up to center of pattern.
3. Settle horse for approximately 10 seconds. Start lope. Circles should be made inside the end markers.
4. & 5. Ride two circles to the right. The first circle, small and slow; the second, larger and faster.
6. & 7. Ride two circles to the left. The first circle, small and slow; the second, larger and faster.
8. Left rollback over hocks (should be made past far end marker).
9. Right rollback over hocks (should be made past near end marker).
10. Stop (should be made past center marker). Let horse settle. Then, in approximate area of stop, do the spins.

11. Do one 360° spin, either left or right.
12. Do one 360° spin in the direction opposite than done in step 11.
13. Walk to the judge and stop for inspection until dismissed.
14. The bridle may be dropped, at the judge's discretion.

I. Western Riding

1. Western riding is neither a stunt nor a race, but it should be performed with reasonable speed. It is the performance of a sensible, well mannered, free and easy moving horse. The horse will be judged on quality of gaits, changes of leads, response to the rider, manners, disposition, and intelligence.

2. Credit shall be given for and emphasis placed on smoothness, even cadence of gaits (i.e. starting and finishing pattern with the same cadence), and the horse's ability to change leads precisely and easily, rear and front, at the center point between markers. Gaits are to be performed as follows. The horse should have a relaxed head carriage, showing response to the rider's hands, with a moderate flexion at the poll. No horse is to be penalized for the manner in which it carries its tail nor for normal response with its tail to cues from its rider or when changing leads. A judge may, at their discretion, penalize a horse for excessive or exaggerated switching or wringing of the tail or for a seemingly "dead" tail that merely dangles between the legs and does not show normal response.

3. Either Pattern #1 or #2 may be used. It is essential that judge and exhibitors adhere to whichever pattern is selected.

a. On the pattern, the short, double line represents a swinging gate, which is optional, or a cone, which is mandatory. If the gate is used, the following will apply. The horse must put the rider in a position to open, pass through, and close without dismounting. It may be located in any part of the arena and should be one which will not endanger horse or rider.

b. The eight (8) small circles represent markers (pylons or cones recommended). These should be separated by a uniform measure distance of not less than thirty (30) nor more than fifty (50) feet on the side with five (5) markers (see diagram). The judge is responsible for correctness of pattern.

c. The rectangle represents an obstacle (one small log recommended), minimum of eight (8) feet in length.

d. The long and sometimes twisting line indicates the direction to travel and the gaits at which the horse is to move.

(1) The dotted line (.) indicates the walk.

(2) The dashed line (- - - - -) indicates the trot.

(3) The solid line () indicates the lope.

- e. The exhibitor will put their horse through the gate (when gate is used), and then proceed on the routine as indicated by the pattern. Any horse not following the exact pattern will be disqualified.
- f. The judge may require an exhibitor to repeat or reverse any part of the routine.
4. Except for junior horses shown with a hackamore or snaffle bit, only one hand may be used on reins, and hands must not be changed except to negotiate the opening of the gate if the gate is in such a position as to justify the change of hands on reins. When a romal is used it means an extension of braided material attached to closed reins. Hand is to be around reins. Index finger only between split reins is permitted.
5. Scoring will be on a basis of zero (0) to one hundred (100), with seventy (70) denoting an average performance.
- a. Scoring guidelines to be considered: Points will be added to or subtracted from each required maneuver on the following basis, ranging from plus one (1) point to minus one (1) point.
- (1) +1 - Excellent
 - (2) +1/2 - Good
 - (3) 0 - Average
 - (4) -1/2 - Poor
 - (5) -1 - Very poor
- b. Pattern #1 consists of nine (9) maneuvers
- (1) Gate or cone.
 - (2) Walk/transition to jog/log.
 - (3) Jog/transition to lope.
 - (4) Line (side) lead changes (+/- 1 point per change).
 - (5) First two crossing lead changes (+/- 1 point per change).
 - (6) Log (lope).
 - (7) Second two crossing lead changes (+/- 1 point per change).
 - (8) Lope/stop/back, minimum of 10 feet.
 - (9) Overall pattern accuracy and smoothness (+/- 1 point).
- c. Pattern #2 consists of twelve (12) maneuvers
- (1) Walk; transition to jog; jog over log.
 - (2) Transition to lope.
 - (3) First crossing change.
 - (4) Second crossing change.
 - (5) Third crossing change.
 - (6) Circle and first line change.
 - (7) Second line change.
 - (8) Third line change.
 - (9) Fourth line change and circle.
 - (10) Lope log.
 - (11) Lope; stop; and back a minimum of ten feet.
 - (12) Overall pattern accuracy and smoothness (+/- 1 point).
6. Scoring will be as follows:
- a. A contestant shall be penalized for the following:

- (1) Releasing gate due to horse's disobedience, knocking over gate, unable to complete gate - 5 points.
 - (2) Use of free hand to instill fear in horse - 3 to 5 points.
 - (3) Breaking gait at lope, including simple lead change - 3 points per infraction.
 - (4) Failure to change leads - 3 points.
 - (5) Additional lead changes anywhere on course - 3 points.
 - (6) Failure to take prescribed gait where pattern designates - 2 points.
 - (7) Breaking gait at walk or trot - 1 point.
 - (8) Hitting log - 1 point.
 - (9) Ticking (light touch) log - 1/2 point.
 - (10) Failure to change lead behind:
 - (a) from 1/2 stride up to the cone - 1/2 point;
 - (b) to next change - 1 point.
7. A horse going off pattern is disqualified. Off pattern is any of the following:
- a. An incomplete pattern.
 - b. Incorrect order of maneuvers.
 - c. Knocking over markers.
 - d. Passing on wrong side of marker.
 - e. Missing the log.
 - f. Execution of four simple lead changes or failure to change leads (defined as a stop or hesitation or loss of forward movement).
8. The following characteristics are considered as faults and should be judged accordingly:
- a. Opening mouth excessively or raising head on maneuvers.
 - b. Anticipating signals or early lead changes.
 - c. Stumbling.
 - d. Losing stirrup or holding on.
 - e. Any unnecessary aid given by the rider, such as unnecessary talking, petting, spurring, quirting, or jerking of the reins.
 - f. Failure to start the lope within twenty (20) feet of the log after crossing it at the jog.

Western Riding Class Pattern #1

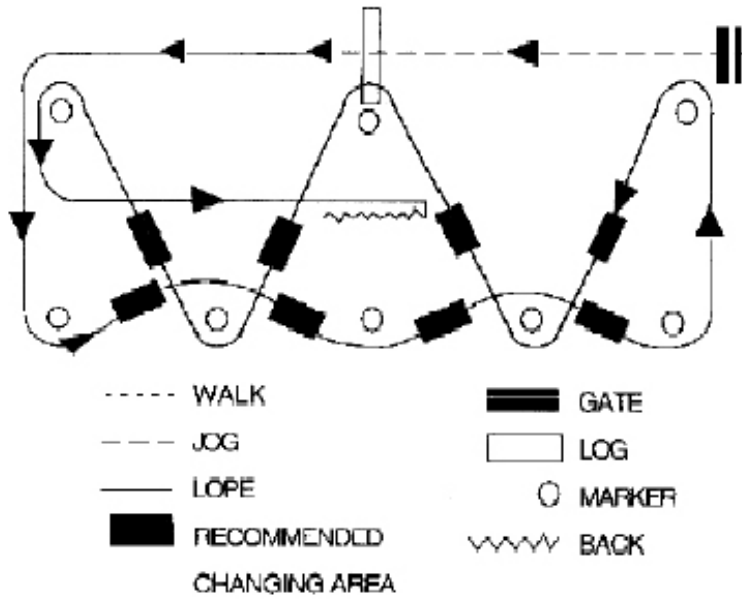

Western Riding Class Pattern #2

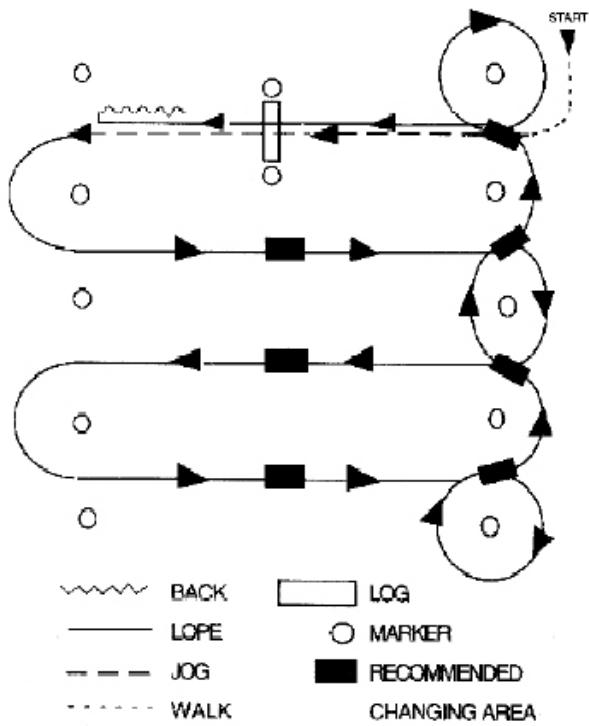

J. Ranch Horse

1. Horses are to be shown over a prescribed course in which horses must work a gate, walk over logs, pass over a bridge, jump a 12" jump, show speed in reining, work rope from full breakaway, complete a sliding stop, and load in and out of a parked trailer.
2. Horses are to be judged on performance, manners, conformation, and appointments.
3. Horses going off pattern will be disqualified.

Ranch Horse Pattern

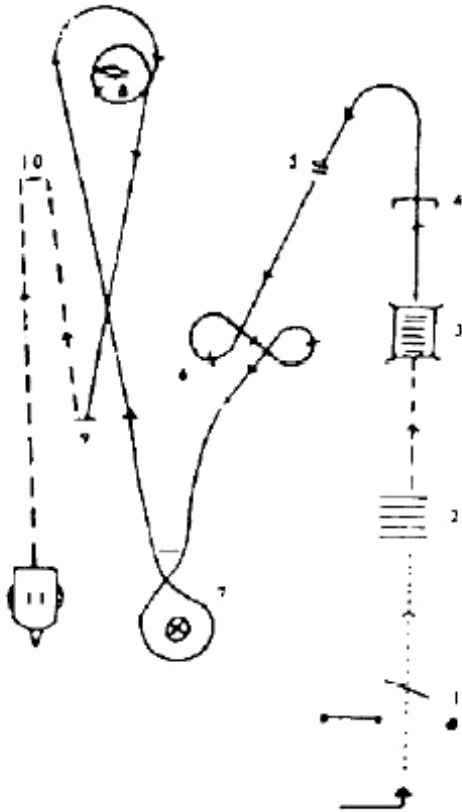

1. On entering the arena, the rider opens, passes through, and closes the gate.
2. Walks over logs.
3. Trots to and walks over bridge.
4. Lopes to and over 12-inch jump.
5. Stops, takes down coiled rope.
6. Lopes with speed a tight and fast figure eight.
7. Lopes in and around log and barrel.
8. Makes two fast turns around barrel, coming out in a full breakaway.
9. & 10. Comes to a sliding stop as coiled rope is pitched out and horse works rope as rider dismounts. Rider then remounts and walks to trailer.
11. Rider dismounts and loads horse in and out of parked trailer.

Working Cowhorse Pattern #1

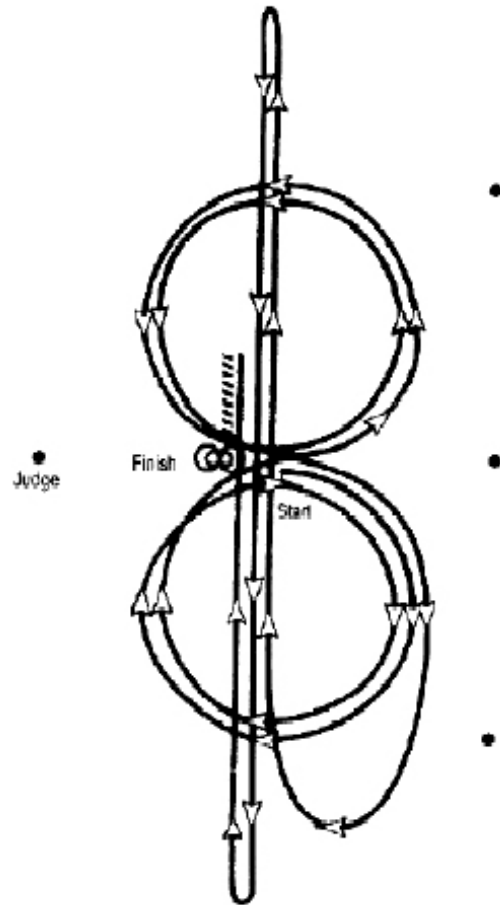

The judge shall indicate the length of the pattern with markers. Markers within the area of the pattern will not be used.

1. Beginning at the center, facing right wall of fence, begin on the right lead and do two circles to the right of moderate size and speed
2. At the center of the arena, change leads and do two (2) circles to the left both of moderate size and speed
3. At the center of the arena, change leads
4. Go to the end of the arena without stopping or breaking gait, and start the rundown near the approximate center of the arena; run the length of the arena past marker
5. Do a square, sliding stop, hesitate
6. Turn to the left and begin a run to the opposite end of the arena; run length of the arena past the marker
7. Do a square, sliding stop, then hesitate
8. Turn to the right, and begin a run down past the center of the arena

9. Do a sliding stop, and back to the center of the arena or at least ten (10) feet. Let horse settle in approximate area of stop
10. Do a two spins (360°) to right
11. Do a two spins (360°) to the left
12. Hesitate to show completion of pattern

10. Back to center of arena; minimum ten (10') to fifteen (15') feet
11. Do a spin (360°) right or left
12. Do a spin (360°) in the opposite direction
13. Approach judge for inspection and dismissal

Working Cowhorse Pattern #2

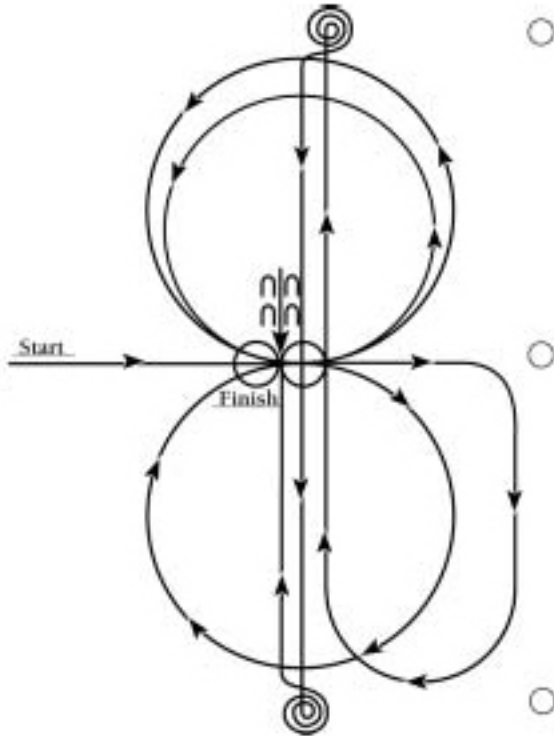

The judge shall indicate the length of the pattern with markers.

Markers within the area of the pattern will not be used.

1. Begin at center of arena facing right wall of fence. Begin on right lead and complete a circle to right away from the judge
2. At center of arena, change leads and do two (2) circles to the left, of approximately the same size
3. At center of arena, change leads
4. Continue around the arena to the right, without stopping or breaking gait, start the run down near the approximate center of the arena. Run full length of arena
5. Do a square sliding stop, hesitate
6. Do two and one half (2-1/2) spins right
7. Run full length of arena to a square sliding stop, hesitate
8. Do two and one half (2-1/2) spins left
9. Run down past center of arena to a square sliding stop

K. Bit Measurement

See illustrations below

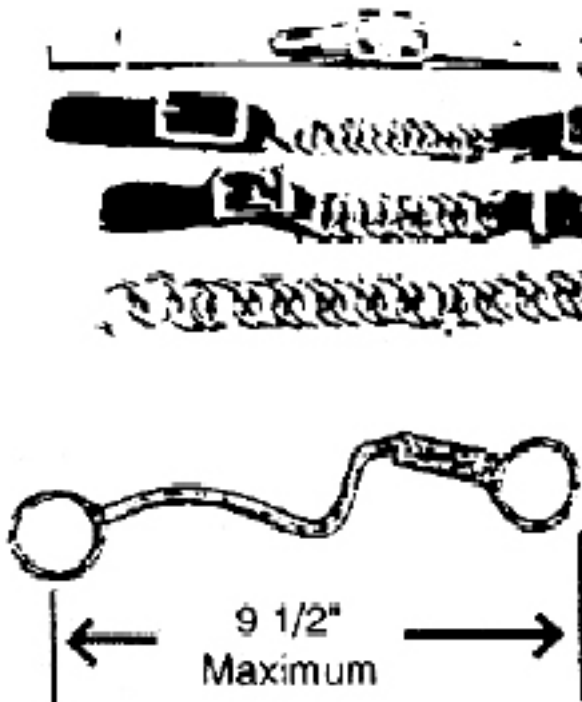

Correct method of measuring overall bit length. A vertical line from the uppermost part of the headstall slot to the rein ring.

RULE 70

Cattle Working Classes

A. General

1. Except in Cutting and Roping events, the general information, appointments of horse and rider, and method of holding reins shall be the same as in the Western Division

2. In Roping events, a mechanical hackamore and a tie-down may be used. However, the judge may prohibit the use of equipment he/she considers severe or inhumane.

B. Working Cow Horse

1. Judging emphasis.

a. Both the cattle-working part and the reining part of this event are mandatory.

b. Emphasis on the cow work scoring portion shall be based on the horse maintaining control of the cow at all times, exhibiting superior cow sense and natural cow-working ability without excessive reining or spurring.

c. Failure of an exhibitor to at least attempt to complete the cow work portion of the class, as well as

the reined work, will result in the exhibitor not being considered an entry in the class.

d. A horse which attempts to complete the cow work, but does not finish for any reason other than the two (2) minute time limit or Rule 67.B.2.e. and f. will be scored accordingly, at the judge's discretion.

e. Any horse going off patterns in the reined work receive a score of zero (0).

f. A horse which attempts both the reined work and the cow work portions may be placed, even if disqualified in one portion of the class. (Example: If a horse is disqualified and receives a 0 score for the reined work, but scores a 70 for the cow work, its total score would be a 70, and the horse would be eligible for placing.)

2. Scoring will be on the basis of zero (0) to one hundred (100), with seventy (70) denoting an average performance.

a. The same basis of scoring shall apply to both the reined work and cow work.

b. The following characteristics are considered as faults:

(1) Exaggerated opening of the mouth.

(2) Hard or heavy mouth.

(3) Nervous throwing of the head.

(4) Lugging on the bridle.

(5) Halting or hesitation while being shown,

particularly when being run out, indicating anticipation of being set up, which is characteristic of an overtrained horse.

(6) Touching the horse or saddle with the free hand, except that during the cow working portion of the class, the rider may hold onto the horn.

c. The characteristics of a good working cow horse are:

(1) Good manners.

(2) The horse should be shifty, smooth, and have its feet under it at all times; when stopping, the hind feet should be well under the horse.

(3) The horse should have a soft mouth and should respond to a light rein, especially when turning.

(4) The head should be maintained at its natural position.

(5) The horse should be able to work at reasonable speed and still be under the control of the rider.

d. The horse shall be penalized for general bad manners, such as:

(1) Biting, striking, or running over the cow, 3 points.

(2) Horses that run past the cow, for every horse's length past the cow, 1 point.

(3) Hanging up on the fence, 3 points.

(4) Exhausting the cow before circling, 3 points.

(5) Failure to hold the cow at the end of the arena, 3 points.

(6) Failure to show sufficient control of the cow while circling, 2 points.

e. Any horse that is out of control while working, thus endangering the rider or crossing the path of the cow, shall be called off the cow and receive a score of zero (0).

f. Any horse that runs over a cow, causing a fall of horse and rider, shall terminate work and receive a score of zero (0).

3. In the event of a tie, the entry with the highest cow work will be declared the winner.

4. The fall of the horse and/or rider while being shown in either cow work or reined work shall not eliminate the entry.

5. Pattern selection

a. In a IQHA approved Working Cow Horse class, horses shall be worked on one of the IQHA approved Cow Horse patterns.

b. Each contestant will cause their horse to travel at the gait indicated for each part of the pattern.

c. When judging reined work, the judge should refer to the reining portion of the handbook for guidelines.

C. Cutting

1. Cutting classes shall be judged in accordance with the class rules of the National Cutting Horse Association in all areas where there are no IQHA rules applicable. All payback schedules shall follow IQHA guidelines.

2. Time limit of 2-1/2 minutes per entry.

3. Classes are to be judged on the ability of the horse to enter the herd, bring out a cow with minimum disturbance, work the cow toward the center of the arena with expression and concentration, but without malice. Once a cow is removed from the herd with light rein contact, the horse should work on a loose rein.

4. Classes are to be scored on a point basis of 0 to 100 points, with 70 points denoting an average performance.

D. Calf Roping

1. Calf roping events will be held under the usual common rodeo standards and conditions. Horses must start from behind a barrier. Only the performance of the horse is to be judged. Time of the roper will not be counted for or against the horse. A time limit of one (1) minute for each contestant will be allowed from the time the calf leaves the chute.

2. The roper may throw only two loops. If more than one loop is thrown, the roper must recoil the rope and build the additional loop. To encourage safety, use of a second rope will not be allowed. Any catch that holds is legal, but the rope must remain on the calf until the tie is completed and the roper has mounted their horse and ridden forward, leaving slack in the rope. Once the rider has ridden forward one step and loosened the rope, the run is complete. If the calf is

jerked down by the horse, it must be allowed to regain its feet and the roper must rethrow the calf by hand, cross any three (3) feet and tie with no less than one (1) complete wrap and a half-hitch. If the calf is jerked down, over backwards, so that all four feet are in the air at the same time, this will be cause for disqualification. Failure of the calf to stay tied until the roper has remounted and ridden forward to loosen the rope shall disqualify the entry.

3. A maximum of one minute or two loops, whichever comes first, will be allowed. If both loops are missed, roper will retire from arena with no score. Rope must be run through a foul rope around horse's neck in a manner to prevent the horse from running off and dragging the calf.

Dragging the calf more than 10 feet will result in disqualification. In calf roping contests only the roper may touch the calf while the horse is being judged. Roper may dismount from either side and leg or flank the calf.

4. Breaking the barrier, or any unnecessary whipping or spurring, jerking reins, talking, or any noise making, clapping, jerking the rope, or any unnecessary action to induce the horse to perform better, will be considered a fault and scored accordingly. If, in the opinion of the line judge, the exhibitor is fouled by any moving part of the chute, barrier, etc., ropers shall get their calf back, providing exhibitor declares himself by pulling up immediately. The contestant shall not attempt to rope the animal until the barrier flag has been dropped. Any attempt by a contestant to position their horse behind the barrier, enabling the contestant to rope the animal without attempting to leave the barrier (box), shall be considered a disqualification. At the judge's discretion, a rerun may be given if the animal being roped leaves the arena or in the event of a malfunction of the chute or barrier.

5. Horses are to be judged on manners behind the barrier, scoring, speed to calf, rating calf, working the rope, and manners while roper is returning to horse after tie has been completed. Scoring is to be done on a point basis of 0 to 100 points, with 70 points denoting an average performance.

E. Dally Team Roping, Heading

1. Dally team roping events will be held under the usual common rodeo standards and conditions. Only the heading horse shall be started and judged behind a barrier. Only the performance of the horse is to be judged. A horse shall be allowed to show in Heading or Heeling, or both. However, the choice of events in which the horse is competing during the run must be declared before the horse enters the arena. Three refusals into the roping box will be cause for disqualification.

2. A marker is to be placed on the fence at a distance which shall be at the discretion of the judge. In both heading and heeling the contestant must let the steer run past the marker before roping. This is to demonstrate the ability of the horse to rate the steer.
3. The head catch must be around both horns, half head, or around the neck. The following catches are illegal: honda passes over one horn and loops the other, loop crosses itself on the head catch, or loop is in steer's mouth. Riders are to stay mounted, and when both ropes are dallied and both horses are facing the stretched steer, the run is completed. The rope must be wrapped around the saddle horn at least one (1) complete turn before it is considered a dally. Riders fifty (50) years of age and over are permitted to have their rope tied onto the saddle horn with the use of a quick release device when heeling only. If a header or heeler drops their rope, the contestant being judged will receive no score.
4. When the heading horse is being judged, the roper may throw two loops. If more than one loop is to be thrown, the roper must recoil the loop. If the roper fails to catch within the one-minute time limit, he/she will retire from the arena with no score.
5. Breaking the barrier or any other actions listed in calf roping above will be considered a fault and scored accordingly. If, in the opinion of the line judge, the exhibitor is fouled by any moving part of the chute, barrier, etc., ropers shall get their steer back, providing exhibitor declares himself by pulling up immediately. The contestant shall not attempt to rope the animal until the barrier flag has been dropped. Any attempt by a contestant to position their horse behind the barrier, enabling the contestant to rope the animal without attempting to leave the barrier (box), shall be considered a disqualification. At the judge's discretion, a rerun may be given if the animal being roped leaves the arena or in the event of a malfunction of the chute or barrier.
6. Horses are to be judged on manners behind the barrier and at all other times, rate of speed to steer, ability of horse to rate, check, turn, and set steer in position for heeler. Classes are to be scored on a point basis of 0 to 100 points, with 70 points denoting an average performance.
7. Disqualification — In all team roping events, it is an automatic disqualification when both the header and heeler fail to complete both catches within one (1) minute from the time the steer leaves the chute.

F. Dally Team Roping, Heeling

1. Dally team roping events will be held under the usual common rodeo standards and conditions. The heading horse must start behind barrier. Only the performance of the horse is to be judged.

2. The heel catch is defined as a catch which holds from behind the steer's shoulder and back, around the flank, or on one or both heels, but not by the tail only. Any catch made by the header not being judged must be around both horns, half head, or around the neck. The following catches are illegal: honda passes over one horn and loops the other, loop crosses itself on the head catch, or loop is in steer's mouth. Riders are to stay mounted, and when both ropes are dallied and both horses are facing the stretched steer, the run is completed. The rope must be wrapped around the saddle horn at least one (1) complete turn before it is considered a dally.

Riders fifty (50) years of age and over are permitted to have their ropetied onto the saddle horn with the use of a quick release device when heeling only. If a header or heeler drops their rope, the contestant being judged will receive no score.

3. Breaking the barrier, or any unnecessary whipping or spurring, jerking reins, talking, or any noise making, clapping, jerking the rope, or any unnecessary action to induce the horse to perform better, will be considered a fault and scored accordingly. If, in the opinion of the line judge, the exhibitor is fouled by any moving part of the chute, barrier, etc., ropers shall get their steer back, providing exhibitor declares himself by pulling up immediately. The contestant shall not attempt to rope the animal until the barrier flag has been dropped. Any attempt by a contestant to position their horse behind the barrier, enabling the contestant to rope the animal without attempting to leave the barrier (box), shall be considered a disqualification.

At the judge's discretion, a rerun may be given if the animal being roped leaves the arena or in the event of a malfunction of the chute or barrier.

4. The heeler may throw two loops. If more than one loop is to be thrown, the roper must recoil the rope. If the roper fails to catch within one-minute time limit, he/she will retire from the arena with no score.

5. Horses are to be judged on manners at all times, ease of turning and preparing for the heeler's position to throw the loop, jerk the steer, and keep the rope tight in a backing position. Classes are to be scored on a point basis of 0 to 100 points, with 70 points denoting an average performance. Three refusals into the roping box will be cause for disqualification.

6. Disqualification - In all team roping events, it is an automatic disqualification when both the header and heeler fail to complete both catches within one (1) minute from the time the steer leaves the chute.

G. Steer Stopping

- 1.** Horses to be judged on manners behind the barrier and at all times. The horse shall be judged on the rate of speed to steer, ability of horse to rate, check, stop straight and to stop and turn the steer to face horse.
- 2.** There is a time limit of one (1) minute or two (2) loops, whichever comes first. If roper fails to catch, he/she will retire from the arena with no score.
- 3.** Classes shall be scored on a point basis of 0 to 100 points, with 70 points denoting an average performance. Any unnecessary whipping, jerking of reins, talking or any noise making, slapping, jerking of rope or any unnecessary action to induce the horse to perform better, will be considered a fault and scored accordingly.

H. Team Penning

- 1.** A team of horses must cut out from the herd and pen within a two (2) minute time limit three (3) head of cattle with the assigned (same) identity number or colored neckband.
- 2.** Once committed to their cattle the team is completely responsible for their animals. A team exhibiting any unnecessary roughness to the cattle or horses, or unsportsmanlike conduct, will be disqualified. No hazing or popping of romal or reins on chaps will be allowed.
- 3.** To be judged on fastest time.
- 4.** Complete rules may be obtained from the IQHA business office. Points will awarded to each IQHA registered animal on placing teams.
- 5.** Further information available from the United States Team Penning Association, PO Box 161848, Fort Worth, TX, 76161.

RULE 71

Hunter Seat Classes

A. General — refer to general show rules

- 1.** Saddle — Any acceptable Hunter Seat or forward seat saddle. Breastplates optional.
- 2.** Bridle — Snaffle, Pelham, Kimberwick (single or double rein), or full bridle are permitted in all Hunter Seat classes. Full bridle must be ridden with double reins. Pelham (double rein curb type) must be ridden with double reins unless bit converters are used to allow the use of a single rein. Copper wrapped and twisted wire bits are allowed, but must gauge a minimum diameter of 5/16 inch when measured 1 inch in from cheek. Any bit with sharp edges will be disallowed. A judge may, at their own discretion, penalize a horse with non conventional types of bits or nose bands in any class. In pleasure and hunter classes, a cavesson type nose band shall be used. In jumper classes, a jumping (not western or mechanical) Hackamore is permitted,

as well as cavesson type, dropped flash (a combination of a cavesson nose band and a dropped nose band attachment) or crossed (made entirely of leather) nose band.

- 3.** Martingale — In pleasure and under saddle classes, martingales are prohibited. In hunter over fences and jumper classes, martingales are optional.
- 4.** Pleasure horses and hunters shall be serviceably sound and shown without artificial appliances. Jumpers shall be serviceably sound.
- 5.** Boots — In pleasure and all hunter classes, boots or bandages are prohibited. In the case of inclement weather, show management may permit the use of bell boots only for hunters over fences. In jumper classes, horses may use protective boots and/or bandages on both front and rear legs.
- 6.** Hand Gallop — No more than eight horses at a time in any class, including command classes.
- 7.** Refer to definition of snaffle bits under Snaffle Bit Rule for specifications.
- 8.** Breakage — In cases of broken equipment in hunter over fences and jumper classes, the rider may either continue without penalty or stop and correct the difficulty, in which case he/she will be penalized 3 faults which will be non-cumulative. In case of loss of shoe, rider may either continue without penalty or be eliminated. In pleasure or hunter under saddle classes, the 7-minute rule in regard to breakage of equipment or casting a shoe shall apply.
- 9.** Dress — Riders shall wear hunt coat, of dark conservative colors (no reds, pinks, etc.), breeches, boots, stock tie, choker or necktie and hunt cap or hunt bowler (adults only). Gloves, spurs, crop or bat (not to exceed 48") optional. Safety helmets with chin straps are recommended for all classes.
- 10.** Manes — It is recommended that entries be shown with natural. Shortened mane and tail is allowed for stock types. Roached mane is prohibited.
- 11.** Braids — Hunter style braiding; forelock and mane or forelock, mane and tail is optional in all classes. In hunt tradition the tail is never braided unless the mane and forelock are also braided. The forelock is always braided when the mane is braided. The fact that an entry is or is not braided shall not be taken into consideration in the judging of a class, but horses braided in a non-conforming manner shall be penalized.
- 12.** Classes using Hunter Seat equipment/attire are open to all types.
- 13.** Hunter Seat and Side Saddle Seat English Pleasure and equitation events may be combined at the option of Show Committees.
- 14.** Gaits
 - a.** Hunter Seat English Pleasure
 - (1)** All gaits to be smooth, fluid, and efficient, without excessive knee action or short choppy strides. Faults

would include too much movement on the forehand; behind the bit or over-collection; poll lower than withers; lazy, rushing, or inconsistent gaits. Any tendency to move in a western style jog, jog trot, or lope must be penalized.

(2) Walk: free, ground-covering four beat gait; rhythmic and flat-footed. Trot: true forward-moving two beat gait; cadenced and balanced; extreme speed to be penalized. Canter: true forward moving three beat gait; smooth, balanced, and straight on both leads.

b. Hunter Under Saddle, Hunter Over Fences, and Hunter Hack

(1) All gaits to be smooth, fluid; long and ground-covering strides, without excessive knee action or short, choppy strides. Appearance to be well-balanced and able to cope with jumping, turning, rolling terrain, and natural ground conditions. All hunters should be able to maintain an even hunting pace, collect smoothly in transitions, and stop and stand quietly from any gait. Faults would include too much movement on the forehand; behind the bit or over-collection; poll lower than withers; lazy, rushing, or inconsistent gaits. Any tendency to move in a western style jog, jog trot, or lope must be penalized.

(2) Walk: free, ground-covering four beat gait; rhythmic and flat-footed. Trot: flowing two beat gait, cadenced and balanced; extreme speed to be penalized. Canter: moderately collected three beat gait; smooth and straight on both leads. Hand gallop: long-striding, but well-balanced and mannerly; there should be a noticeable difference between canter and hand gallop; extreme or hazardous speed or behavior must be severely penalized.

c. Show Hack and Dressage

(1) All gaits to be correct and pure. Good balance, freedom of movement, lively impulsion (but not high action), and true, straight movement needed. Correct engagement and rhythm is the basis for balanced, elastic, and cadenced movements. Faults include pacing in the walk or a four beat canter; hollow back; moving on the forehand; behind the bit or over-collected; poll level with or lower than withers; excessive action; inconsistent gaits. Any tendency to move in a western style jog, jog trot, or lope must be penalized.

(2) Walk: good engagement with four clean, evenly spaced beats. Trot: regular and cadenced, with good balance; there must be two clean beats. Canter: well balanced, with three clean beats and straight on both leads.

B. English Pleasure Hunter Seat

1. Entries should give the appearance of being a pleasure to ride. To enter the ring at a normal trot.

Classes may not be pre-loaded except when restricted to Stock Type Horses.

2. To be shown at a walk, normal trot and canter both ways of the ring.

Extended trot and hand gallop may be required at the judge's discretion. May be asked to back. Entries are required to walk prior to execution of change of gait.

3. To be judged as pleasure horses on performance, manners, conformation, and suitability.

C. Hunter Under Saddle

1. Entries should give the appearance of being suitable for use as field and/ or arena hunter over fences. To enter the ring at a normal trot. Classes may not be pre-loaded except when restricted to Stock Type Horses.

2. To be shown at a walk, normal trot and canter both ways of the ring. Required to walk prior to execution of gaits. Light contact with horse's mouth is required. Horses should be obedient, alert, responsive to move freely. They shall not be eliminated for slight errors. Horses may be asked to back.

3. Working Hunter Under Saddle — To be judged as hunters on the flat on performance, soundness, and suitability.

4. Conformation Hunter Under Saddle — To be judged as hunters on the flat on performance, conformation, and suitability.

5. Horses shall be required to hand gallop, one way of the ring, in a collected manner. No more than eight horses may hand gallop at a time.

D. Hunter Over Fences

1. Judging

a. Performance — An even hunting pace, manners, jumping style, together with faults and way of moving over the course, as well as when being jogged for soundness, will be considered in judging performance.

b. Conformation — Quality, substance and soundness will be considered in judging conformation.

c. Form — Judge shall penalize unsafe jumping and bad form over fences, whether touched or untouched.

d. Entries must return to the ring for conformation or soundness judging in the same complete bridle in which they have performed or they may be refused an award.

e. Horses shall not be requested to show at a walk, trot and/or canter or to re-jump the course or any part thereof.

2. Fences and Courses

a. Course — A hunter course shall be a course which management deems a fair test of a hunter. Fences shall simulate obstacles found in the hunting field such as natural post and rail, brush, gate and chicken coop. Jumps such as triple bar, hog's back or targets

are prohibited.

b. Handy — In handy classes, fences should simulate those found in trappy hunting country. The course should have at least two changes of direction and require entries to trot over one fence toward the end of the course.

c. Ground Line — A ground line is recommended for all fences.

d. Distances — In all hunter classes over fences, distances between fences shall be set as 12' multiples (i.e., an in and out with one stride between fences would be 24'; a two stride, 36'). An in and out is considered as two obstacles, but must never be used as a first fence.

e. The top element of all fences must be securely placed so that a slight rub will not cause a knockdown. Fifty percent or more of the fences must be the required height and none shall be more than 2" over or under. Brush jumps may be lower.

f. Posted — All courses must be posted at least one hour before scheduled time of class in a place readily available to exhibitors. The plan or diagram of the course must show the obstacles, which must be taken in the order indicated by numbers, but, apart from this, the rider is not bound to follow a compulsory track. An arrow is used to indicate on the plan the direction in which each obstacle is to be taken.

g. Design — Courses shall consist of at least six fences (a fence may be jumped more than once if so designed), but no more than ten fences, and should have at least one change of direction in all classes and one combination (in and out) in classes 3'3" and over.

h. Heights — The minimum height for any class shall be 2'6". The maximum height for any class shall be 4'0". The Show Committee should take into consideration the quality and experience of horses available in determining the height of fences for each class (i.e., beginning horses use lower fences than more experienced horses, who usually will not jump well if the jumps are too low). The premium list must include the exact height of fences to be jumped in each class (i.e., Fences 3'0").

i. Spread jumps — A spread jump is an obstacle or combination of elements taken in one jump and negotiated in the proper direction.

3. Scoring

a. Circling — Circling once upon entering the ring and once upon leaving is permissible.

b. Touches — Light touches are not to be considered, unless the result of bad form.

c. Knockdowns — An obstacle is considered knocked down when its height is lowered by horse or rider.

Knockdowns are scored as follows:

(1) with any part of horse's body behind stifle — 4 faults.

(2) with any part of the horse's body in front of stifle — 8 faults.

d. Disobediences — Disobediences are scored per class, as follows:

(1) 1st refusal, runout, bolting on course, extra circle or showing an obstacle to a horse — 8 faults.

(2) 2nd refusal, runout, bolting, extra circle, showing obstacle — 8 faults.

(3) 3rd refusal, runout, bolting, extra circle, showing obstacle — elimination.

(4) failure to keep proper course — elimination.

e. Falls — Fall of horse and/or rider in competition shall result in elimination.

f. When an obstacle is composed of several elements in the same vertical plane, a fault at the top element is the only one penalized.

g. In case of a refusal or runout at the second element of an in and out, the competitor may re-jump the first element as well as the second.

4. Working Hunter Over Fences; Open, Handy — To be judged on performance, soundness and suitability.

5. Conformation Hunter Over Fences; Open, Handy — To be judged on performance, conformation and suitability.

E. Jumper

1. Judging

a. Time classes — Time shall be taken from the instant the horse's chest reaches the starting line until it reaches the finishing line. Time shall be taken out while a knocked-down jump is being replaced - that is, from the moment the rider gets their mount in position to retake the jump until the proper authority signals that the jump has been replaced.

b. Responsibility for construction of courses is a function of the Show Committee, but judges should inspect each course after it has been set and inspect any jump that has been reset; and call the Show Committee's attention to anything that would tend to result in unfair or inappropriate courses.

c. Any form of circle or circles, whereby the horse crosses its original track between two consecutive obstacles, stops advancing toward or turns away from the next fence except to retake an obstacle after a disobedience, is considered a disobedience. This is a judgment call. (Note: Coming sideways or zigzagging toward an obstacle does not constitute a disobedience unless the horse passes or turns its back to the next obstacle or the finish line).

2. Fences and Courses

a. Course — The first criterion of a good course is its suitability to the capabilities of the horses which will jump it and to conditions of the class. Obstacles should be attractive and varied. Care should be taken to insure that all fences represent fair, "jumpable" tests of a horse's ability and training.

b. All fences and/or their components must be capable of being knocked down and should be neither so light or poorly supported that they fall at a slight touch, nor so heavy or firmly supported that they can hardly be dislodged. A type of standard in which a rail rests on top of the post may not be used.

c. Spread jumps — A spread jump is an obstacle or combination of elements taken in one jump and negotiated in the proper direction. A spread jump is measured from the two outermost top extremities on a line parallel to the ground. As a general rule, it is wise to allow at least 9" differences in the heights of the various elements of a spread jump, which will normally insure that the first element is not too high relative to the highest one. A solid component (i.e., coop, wall, etc.) must not be used as part of the furthestmost element.

d. Combinations — A double, treble, or multiple jump "combination" is composed of two, three or more jumps with a maximum inner distance between them of 39'5", which must be taken in two, three or more successive jumps. The distance is measured from the base of the one jump on the landing side to the base of the next jump on the take-off side.

e. Distances — Distances between fences and between elements of an in and out should be basically the same as for Hunter Over Fences classes.

f. Fences — The types of fences permitted in jumper classes include square oxers, targets, painted rails, triple bars, and hog backs.

Brush jumps must have a clearly visible bar resting on, or placed above or beyond same. An obstacle composed of a single rail is not recommended and may not be used in classes 3'0" or over.

Double crossed poles (i.e., two pairs of crossed poles, with a spread between them) must not be used, and care should be exercised in constructing single crossed poles to prevent abnormal difficulties.

g. Start and Finish — Both a starting line at least 12' from the first obstacle and a finishing line at least 24' beyond the last obstacle must be indicated by two markers, at least 12' apart, set on each end of each line. Horses must cross the starting line mounted between the markers and, to complete a course, they must cross the finishing line between the markers in the proper direction mounted, except in fault and out classes.

h. Posted — Courses must be posted in the same manner as Hunter Over Fences classes.

i. Design — Courses shall consist of at least eight, but no more than twelve fences (a fence may be jumped more than once if so designed). One combination (in and out) and at least one spread type jump must be included in classes 3'3" and over.

j. Heights — The minimum height for any class in the first round shall be 2'9". Classes shall be 2'9" to 3'0" in the first round and not to exceed 3'6" in subsequent rounds with spreads 3'3" to 3'6" (not to exceed 4'0"); 3'0" to 3'3" in first round (not to exceed 3'9") with spreads 3'3" to 3'6" (not to exceed 4'3"); 3'3" to 3'6" in first round (not to exceed 4'3") with spreads 3'6" to 3'9" (not to exceed 4'6"); 3'6" to 3'9" in first round (not to exceed 5'0") with spreads 3'9" to 4'0" (not to exceed 5'0"); 3'9" to 4'0" in first round (not to exceed 5'6") with spreads 4'0" to 4'6" (not to exceed 5'6"); 4'0" to 4'3" in first round (no maximum) with spreads to 5'0" (no maximum). The Show Committee should take into consideration the quality and experience of horses available in determining the height of fences for each class. The premium list must include height and spread for fences and which judging Table, I or II, will be used for scoring.

3. Scoring

a. Jumpers are scored in a mathematical basis, and penalty faults, which include Disobediences, Falls, Knockdowns, Touches, and Time Penalties, as outlined below, shall be incurred between the starting line and the finishing line. Circling once upon entering the ring and once upon leaving is permissible.

b. When a horse makes 2 or more faults at any obstacle, only the major fault counts, or, in the case of equal faults, only one will count, except in case of disobedience, which counts in addition.

c. When an obstacle is composed of several elements in the same vertical plane, a fault at the top element is the only one penalized.

When an obstacle to be taken in one jump is composed of several elements not in the same vertical plane (oxer, triple bar, etc.), faults at several elements are penalized as one fault.

d. When an obstacle requires two or more jumps (in and out), the faults committed at each obstacle are considered separately. In case of a refusal or run-out at one element of an in and out, entry must re-jump the previous as well as the following elements.

e. Disobediences

(1) Refusal — This constitutes stopping in front of an obstacle to be jumped, whether or not horse knocks it down or displaces it.

(2) Run-out — Evading or passing the obstacle to be jumped or the finish line.

(3) Loss of Gait — Loss of forward movement (halt or step backward) by horse after crossing starting line, unless due to refusal or run-out or an order from a judge due to unforeseen circumstances, shall be penalized as a disobedience.

f. Falls — Fall of horse and/or rider shall result in elimination. In Fault and Out classes, if the fall or

disobedience occurs after landing, the horse will be scored as though the fault has occurred at the next approaching obstacle. Even when the penalty of "Elimination" is incurred, the rider will be credited with obstacles already cleared.

g. Knockdowns — An obstacle is considered knocked down when a horse or rider, by contact lowers any part thereof which establishes the height of the obstacle or the height of any element of a spread obstacle, even when the falling part is arrested in its fall by any portion of the obstacle.

h. Touches — Touches shall be scored as outlined in "Table I". At a brush element, the touch of the brush only, without touching the framework or pole on top thereof, is not scored as a fault.

i. Elimination — Any of the following shall result in elimination of the entry:

(1) Failure to enter ring within one minute of being called.

(2) Failure to jump in designated order.

(3) Deliberately addressing an obstacle.

(4) Failure to cross starting line within one minute after signal to proceed.

(5) Jumping obstacle before it is reset or without waiting for signal to proceed.

(6) Competitor and/or horse leaving arena before finishing course.

(7) Three cumulative disobediences (anywhere on course).

j. Ties — Ties involving first place only may be jumped off or owners of tied horses may elect to toss a coin. Horses that are tied for other than first place shall remain tied. Riders may toss a coin for the ribbon unless management provides additional ribbons for tied horses. When tied horses are under one ownership or management, the exhibitor may designate the order of placement. A Judge or Steward shall conduct the breaking of ties when they are to be determined by the tossing of a coin or designation of placement under one management or ownership. Any exhibitor who advises the Judge that he/she will not participate in a jump-off is thereupon placed last of the competitors in that jump-off. Should there be one remaining competitor in the jump-off, he/she is required to attempt at least the first obstacle in order to earn top placement in the jumpoff.

k. Jump-offs — Jump-offs will be held over the original course.

Courses may be shortened for the first jump-off and must be shortened in the event there is more than one jump-off. In classes where there is a spread jump, that fence must remain in all jumpoffs.

Except in Fault and Out classes, when two or more horses incur the penalty of elimination during a jump-off, they remain tied, regardless of the cause of

elimination or the point at which the penalty was incurred. A competitor who withdraws in a jump-off must always be placed after a competitor who has been eliminated in the same jump-off.

4. Tables

a. Table 1 - Touch Classes (Time does not apply in Table 1 classes).

(1) Touch of obstacle with any portion of horse's body behind stifle — 1/2 fault.

(2) Touch of obstacle with any portion of horse's body in front of stifle or with any part of rider or equipment — 1 fault.

(3) Knockdown of obstacle, standard or wing with any portion of horse, rider or equipment — 4 faults.

(4) 1st disobedience (anywhere on course) — 3 faults.

(5) 2nd cumulative disobedience (anywhere on course) — 6 faults.

(6) 3rd cumulative disobedience (anywhere on course) — elimination.

b. Table II — Knockdown Classes (Faults and time)

(1) Faults and eliminations are scored in exactly the same manner as in "Table I" except that touches are not penalized.

(2) Time may be taken in the first round, first jump-off, or second jump-off. Premium list must clearly state at which point in the competition time will be taken.

c. Fault and Out — The winner to be the horse clearing the most jumps without a fault as defined in "Table II". Time does not apply in this class.

F. Hunter Hack

1. Scoring

To be judged:

30% on performance and manners in the rail work;
30% on performance, way of going and manners on individual work;

30% on type, conformation, quality and substance;
10% on appointments

2. Class conditions and rules.

All horses competing shall first be lined up at one side of the arena for instructions from the judge for individual work. The individual work shall consist of no less than the following:

a. Separate from the lineup, canter and proceed to jump two fences.

These fences shall be brush or simply post and rails, with ground line before each fence. If a brush is used, it must be the first fence jumped. Jumps do not have to be set on a line. However, if jumps are set on a line, they must be set 36', 48', or 60' apart or in increments of 12', but no less than 36'. The height of the fences shall not be lower than 2'3" nor higher than 2'9".

b. Hand gallop.

c. Stop at a point at least half-way down the long side of the arena -settle.

d. Back and stand quietly.

e. Return to line up.

Faults over fences will be scored as in working hunter classes. Only horses being considered for an award may be called back for the rail work.

To be shown at a walk, trot and canter both ways of the ring. It is the judge's option to require an exhibitor to extend any gait, to back easily, and to stand quietly while riders dismount and mount. Emphasis shall be placed on actual suitability to purpose. Light contact with horse's mouth is required. Horses should be obedient, alert, responsive and move freely. They should not be eliminated for slight errors. Horse must be brought to a flat-footed walk before changing gaits.

WALK: True and flat-footed for pleasure classes.

TROT: Brisk, smart, cadenced and balanced without loss of form. An extended trot may be called for at the judge's option, but judge may not call for a canter from a trot.

CANTER: Smooth, collected and straight on both leads, with the ability to push on, if so required, into a hand gallop.

3. Appointments

Personal and tack appointments (Refer to Hunter Seat Rules).

I. Show Hack

1. Open to all types. All gaits must be performed both ways of the arena.

2. Tack

a. Any type English saddle may be used.

b. Bridles may be either double, pelham, snaffle, or kimberwick.

c. Martingales, figure-eight or dropped nosebands, protective boots and/or bandages of any kind are prohibited.

d. Leather browbands only, either solid or edged with a maximum of 1/4" trim, are permitted. Flashy or colored browbands, or those of materials other than leather are prohibited.

e. Whips not exceeding 48" and/or spurs are optional.

3. Attire

a. Black jacket or dark coat.

b. Top hat, bowler hat, or conservatively colored hunting cap.

c. White or light tan breeches.

d. White hunting stock.

e. Black boots.

f. Saddle suits and Kentucky jodhpurs are prohibited.

4. Class conditions and rules.

Competitors enter the ring in a counter clockwise direction at the normal walk or normal trot. Light contact must be maintained with reins at all gaits.

A judge may not request that gaits be performed only on snaffle or curb.

Judges are required to consider the performance at each gait equally in adjudicating this class. The Show Hack is a suitable section for the well trained animal. Show Hacks must be balanced and show vitality, animation, presence, supreme quality. Soundness is required. The collected and extended gaits must be called for; i.e., collected walk, extended walk, normal walk; collected trot, extended trot, normal trot; collected canter, extended canter, normal canter and hand gallop. At the discretion of the judge, horses while on the rail may be asked to halt and rein-back. A Show Hack shall be able to perform all of these gaits with a noticeable transition between the normal, collected, and extended gaits. The horse must be under complete control and easily ridden.

Obedience to the rider is of prime importance. If the horse exhibits clear transitions in a balanced and level manner, appearing to be giving a comfortable and pleasurable ride, he is performing correctly for this class.

a. Walk, a four-beat gait: Straight, true and flat-footed.

1. Normal Walk: Regular and unconstrained, moving energetically and calmly forward.

2. Collected Walk: Strides are shorter and higher than at the normal walk. The head approaches the vertical, but should never move behind it. Pacing is a serious fault.

3. Extended Walk: The horse is allowed to lengthen frame and stride while rider maintains light rein contact. The horse should cover as much ground as possible without rushing.

b. Trot, a two-beat gait: Free-moving, straight, rider maintaining light contact with horse's mouth at all times.

1. Normal Trot: Light, crisp, balanced and cadenced, with rider posting.

2. Collected Trot: The horse's stride is shorter and lighter, maintaining balance and impulsion. The neck is more raised and arched than at the normal trot as head approaches the vertical line, never moving behind it.

Rider is sitting.

3. Extended Trot: Maintaining the same cadence and performing at medium speed, the horse lengthens its stride as a result of greater impulsion from the hindquarters.

Horse should remain light in rider's hand as it lengthens its frame. Rider is posting.

c. Canter or three-beat gait: Straight on both leads, smooth.

1. Normal Canter: Light even strides, should be moved into without hesitation.

2. Collected Canter: Marked by the lightness of the forehand and the engagement of the hindquarters, the collected canter is characterized by supple, free shoulders. Neck is more raised and arched than in a normal canter as the head approaches the vertical line, never moving behind it.

3. Extended Canter: Maintaining the same cadence, the horse lengthens its stride as a result of greater impulsion from the hindquarters. Horse should remain light in rider's hand as it lengthens its frame period.

d. Hand Gallop: The hand gallop is performed with a long, free, ground covering stride. The amount of ground covered may vary between horses due to difference in natural length of stride. The distinction between hand gallop and extended canter is, the latter being the ultimate linear extension of stride within the hand of the rider; the hand gallop being a looser, more free elongation of stride and frame of the horse. A decided lengthening of stride should be shown while the horse remains controlled, mannerly, correct and straight on both leads. Extreme speed to be penalized.

5. Mane and tail may be braided, but must not be roached.

6. Fall of horse or rider is cause for elimination.

7. Shoeing regulations must be consistent with type shown.

8. Scoring

To be judged:

55% on performance;

20% on quality;

15% on conformation;

10% on manners.

RULE 72

Eventing

Eventing includes two or three competitions from the following branches of equitation: Dressage, Endurance and Jumping. The pinnacle of Eventing is the Three-Day Event ("Concours Complet d'Equitation") of the Olympic Games.

A. General

1. Eventing organizations are the United States Combined Training Association and the United States Equestrian Team.

2. Complete Eventing rules may also be found in the USA Equestrian Rule Book.

B. Definitions

1. Three-Day Event — The Three-Day Event comprises three distinct competitions, usually taking place on three days, during which a competitor rides the same horse throughout, namely:

a. A dressage competition.

b. An endurance competition.

c. A jumping competition.

2. Two-Day Event — The Two-Day Event comprises three distinct competitions, usually taking place on two days, during which a competitor rides the same horse throughout, namely:

a. A dressage competition.

b. A jumping competition.

c. An endurance competition.

3. Horse Trial — The Horse Trial comprises three distinct competitions, usually taking place on one day, during which a competitor rides the same horse throughout, namely:

a. A dressage competition.

b. A cross-country competition.

c. A jumping competition.

4. Combined Test — The Combined Test comprises two distinct competitions, taking place on one day, during which a competitor rides the same horse throughout, namely:

a. A dressage competition.

b. A jumping competition.

C. Points

1. No points will be separated from an Eventing score and applied to any other ROM point earning event (i.e., Dressage scores from CT may not be used towards a Dressage ROM).

2. Team or individual gold, silver or bronze medal placings in international events, governed by the current rules of the FEI (Federation Equestre Internationale), will receive points on the following basis:

a. Gold Medal 250 points

b. Silver Medal 200 points

c. Bronze Medal 175 points

d. 4th, 5th, and 6th 150, 125, and 100 points respectively

3. Team or individual gold, silver or bronze medal placings in AHSA recognized Eventing Three-Day Events will receive points on the following basis:

a. Gold Medal 50 points

b. Silver Medal 40 points

c. Bronze Medal 35 points

d. 4th, 5th, and 6th 20, 15, and 10 points respectively

4. Individual placings in non-AHSA Three-Day Events and AHSA or non-AHSA recognized Two-Day Events, Horse Trials or Combined Tests will receive points based on the regular IQHA point scale times the number of days of the competition (i.e., Two-Day Event received double points).

RULE 73

Dressage

The object of Dressage is the harmonious development of the physique and ability of the horse.

The pinnacle of Dressage competition is the Grand Prix de Dressage competition of the Olympic Games.

A. General

1. Dressage organizations are the United States Dressage Federation and United States Equestrian Team.
2. Complete Dressage rules may also be found in the USA Equestrian Rule Book.
3. Point earning levels shall be training level and higher. All three basic gaits are required in any point earning test.

B. Appointments

1. Saddle — An English type saddle with irons is required at all levels. Breastplates are optional.
2. Bridles — All bits must be smooth. Twisted or wire bits are prohibited. Acceptable snaffles include egg-butt, D-ring (racing), full ring with single or double-jointed mouthpiece, full or upper cheek bits with or without keepers and unjointed snaffles. Bits may be covered with rubber or leather.
 - a. For Training, First and Second Level tests, a plain snaffle bridle and a regular cavesson, a dropped noseband, a flash noseband (a combination of a cavesson noseband and a dropped noseband attachment) or a crossed noseband (made entirely of leather) are required.
 - b. For Third and Fourth Level Tests, same as above, or simply double bridle (bradoon and bit with curb chain, lip strap optional).
3. Martingales of any kind, bearing, side or running reins and boots or bandages are prohibited.
4. Horses shall be serviceably sound and shown without artificial appliances.

Horses may be shown shod or barefoot.
5. Dress — Competitors are reminded that neatness should be the first requisite. Conservative solid colors are recommended. Riders shall be dressed the same as the Hunter Seat Division.
6. Braids and manes are the same as the Hunter Seat Division, although traditionally tails are not braided in Dressage.
7. Spurs — At Training, First and Second Level tests, spurs are optional.

Spurs are required when riding Third and Fourth Level tests.
8. Whips — One whip no longer than 4 feet in length including lash may be carried in Training through Fourth Level classes. In all championship classes, whips are prohibited.

C. Arena

1. The Standard Arena is 60 meters (198') long and 20 meters (66') wide.

All Third and Fourth Level tests and Championship classes must be held in a Standard Arena. The Small Arena is 40 meters (132') long and 20 meters (66') wide. The arena should be on as level ground as possible.

Arena measurements are for the interior of the closure.

2. The enclosure itself should consist of a low fence about 0.30 meters (1') high. The part of the fence at "A" should be easy to remove to let the competitors in and out of the arena in a suitable way. If fencing is not available, the enclosure should be marked in such a way as to be clearly visible to competitors and the judge without frightening the horses. Poles laid on the ground would be acceptable.
3. The letters outside the enclosure should be placed about 0.50 meters (20') from the end of the arena opposite the letter "C".
4. The judge (also referred to as the jury) is placed 5 meters (16') from the end of the arena, opposite the letter "C". He/she should be provided with a scoring clerk, table and chairs (some sort of shade is usually provided also, if there is more than one class.)

D. Competitions

1. Salute — At the salute, riders must take the reins in one hand. A lady rider shall let one arm drop loosely along her body and then incline her head in a slight bow. A gentleman rider shall remove his hat and let his arm drop loosely along his body or may render the salute as does a lady rider.
2. Voice — The use of voice or clicking with the tongue during a ride is prohibited.
3. Calling tests — All tests may be called during a competition, except in First Level and above Championship classes, at which time all tests must be ridden from memory. It is the responsibility of the competitor to arrange for a person to announce the test. Lateness and errors in announcing the ride will not relieve the rider from "error penalties".

Unauthorized assistance by anyone, coaching or repeating of movements by caller is prohibited and is cause for elimination.
4. Fall — In the case of a fall of horse and/or rider, the competitor will not be eliminated.
5. Time — A competitor must enter the arena within one minute after the judge has indicated he/she is ready (bell or whistle may be used) for the ride to begin, or be eliminated.
6. Faults — Grinding of the teeth, wringing of the tail, performing with an open mouth, tongue over the bit, nodding, shying or signs of resistance on the part of the horse are faults and may be considered in the marks for each movement as well as in the collective marks.

7. Accuracy — In a movement which must be carried out at a certain point of the arena, it should be done at the moment when the competitor's body is above this point.

8. Elimination — The following are causes for elimination:

- a. Horses which enter the arena with their tongues tied down.
- b. If, during the test, the horse leaves the arena (all four feet outside the fence or line marking the arena perimeter).
- c. A competitor leaving the arena at the end of their ride at any point other than "A".

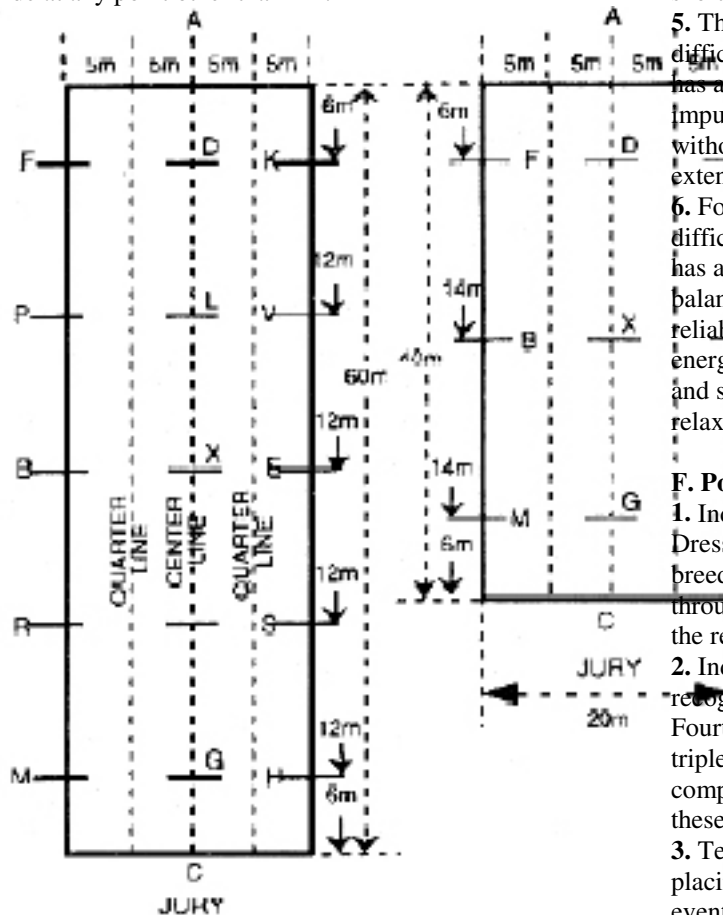

E. Tests

1. The current USDF/USAE tests must be used at all times. These may be obtained from USDF or USAE for a small fee. Ride level and test number must appear in the premium list.
2. Training Level Tests — To introduce the rider and horse to the basic principles of Dressage competition. Horse should display free, rhythmic, forward movement, relaxed and obedient to the aids of the rider, without fight or evasion, stretching into the bit in a calm, receptive manner.

3. First Level Tests — To determine that the correct foundation is being laid for successful training of the riding horse, that it accepts the bit and obeys simple aids of the rider. Horse should move freely forward in a relaxed, rhythmic manner, its spine always parallel to the track of the prescribed movement and showing some lateral bending and quiet transitions.

4. Second Level Tests — To determine that the horse has acquired, in addition to those qualities of the First Level, a degree of suppleness, balance and impulsion. Rider must be able to put the horse on the bit and keep it there without fight or evasion and without shortening the strides. Neck must be relaxed.

5. Third Level Tests — These tests are of medium difficulty and are designed to determine that the horse has acquired an increased amount of suppleness, impulsion and balance, so as to be light in hand and without resistance, enabling the rider to collect and extend its gaits.

6. Fourth Level Tests — These tests are of medium difficulty and are designed to determine that the horse has acquired a high degree of suppleness, impulsion, balance and lightness, while always remaining reliably on the bit. Horse's movements are straight, energetic and cadenced, and the transitions precise and smooth. Horse must show complete obedience, relaxation, collection and extension.

F. Points

1. Individual placings in non-USAE recognized Dressage competition at all Levels and open (all breeds) USAE recognized competitions, Training through Second Levels, will receive points based on the regular IQHA point scale.
2. Individual placings in open (all breeds) USAE recognized Dressage competitions at Third and Fourth Levels will receive points based on triple the regular IQHA point scale. Restricted competitions (i.e., Arabian/ half-Arabian only) at these levels will receive regular points.
3. Team or individual gold, silver, or bronze medal placings in Fifth Level and above FEI International events will receive points, along with fourth through sixth placings, on the following basis:
 - a. Gold Medal 250 points
 - b. Silver Medal 200 points
 - c. Bronze Medal 175 points
 - d. 4th, 5th, and 6th 150, 125, and 100 points respectively
4. Individual placings in open recognized competitions at Fifth Level, Prix St Georges, Intermediate 1, Intermediate 2, Grand Prix special, and musical freestyle will receive points based on five times the regular IQHA point scale (i.e. a first place in a full point-earning class will receive thirty points.)

RULE 74

Side Saddle

A. Appointments shall consist of an appropriate side saddle, either English or Western style, and an appropriate bridle of style depicted. Tie-down or martingale prohibited. Mixed classes allowed.

B. Attire shall be English (formal or informal), Western or period; consisting of coat or vest and skirt, or dress, divided skirt or apron, hat and boots or appropriate shoes. Pantaloon optional. Judges shall give equal consideration to all styles of attire.

C. To be shown at a walk, normal trot if English or jog if Western, and canter or lope. Riders may sit or post the trot.

D. To be judged on manners, performance, quality, and appointments.

RULE 75

Parade Horse

A. Appointments

1. Horses are to be shown with stock saddle, standard bridle, plain or with silver, Mexican or other appropriate equipment. Breastplates, hip drops and serapes are optional.

2. Boots or bandages, any kind of martingale, tie-down or draw reins are prohibited.

3. Horse shall be serviceably sound and shall be shown with full or shortened mane and tail. Roached mane or tail prohibited.

4. Riders shall wear colorful attire of American, Mexican or Spanish origin, consisting of fancy cowboy suit, hat and boots; or dress Western clothing. Spurs, gloves, whip or crop optional.

5. Riders may use either one hand or two hands on reins, but may not change method of holding reins or rein hand during class.

6. Braids – “Saddle horse” style braiding is optional in all classes for all types of horses. Braiding may be fancy (i.e., rosettes), but must be unobtrusive and tasteful. Tail decorations are optional. The fact that an entry is or is not braided shall not be taken into consideration in the judging of a class, but horses braided in a non-conforming manner shall be penalized.

B. Presentation

1. Entries shall enter the ring at a parade trot. Martial music is suggested whenever possible.

2. Entries shall be shown without artificial appliances. There shall be no limitations on the length of toe,

weight of shoe, number or pads or use of lead or weight. Bands or other devices on the hoof are prohibited.

3. Qualifying Gaits.

a. The parade gait shall be true, straight, prancing movement, square, collected and balanced, with hocks well under. Speed shall not exceed 5 miles per hour.

b. The parade trot shall be straight, square, collected and balanced, with hocks well under. Speed shall not exceed 5 miles per hour.

4. To be shown at a walk, either regular or animated, and parade trot, both ways of the ring. Reverse shall be executed at the walk.

To halt and stand quietly from both the walk and parade trot. Entries not required to back.

5. To be judged on performance, manners, appointments, conformation and suitability.

RULE 76

Show Horse

A. Appointments

1. Appointments shall be the same as Parade Horse, except that the hip drops and serapes are prohibited. Colorful appearance of both horse and rider is essential. Silver shall not be given preference in the judging, but attractively presented equipment is desirable.

2. Entries shall be shown without artificial appliances. There shall be no limitations on the length of toe, weight of shoe, number of pads or use of lead or weight. Bands or other devices on the hoof are prohibited.

B. Presentation

1. Horses shall enter the ring at a trot.

2. Qualifying Gaits.

a. The walk shall be animated and elastic. Need not be a flat walk.

b. The trot shall be square, high going, collected and balanced, with hocks well under. Emphasis on action.

c. The canter shall be smooth, easy, collected and straight on both leads.

3. To be shown at a walk, trot and canter, both ways of the ring. Entries must walk prior to execution of trot, canter or reverse. To stand quietly. Entries not required to back.

4. To be judged on performance, manners, appointments, conformation and suitability.

RULE 77

Gymkhana

A. General

1. Unsoundness shall not be penalized in an entry unless it is sufficiently severe to be considered an act

of cruelty. In such a case, management shall bar the entry from further participation.

2. Poles (stakes) shall be approximately 1-1/2" in diameter and of a safe material that will not splinter. Each shall be from 6' to 7' high, with a safe, stable stand for ballast. Each shall be painted so that it is easily distinguished from the background (rail, tanbark, etc.). Official base should be 12" to 14" in diameter.

3. Barrels shall be of the size of a fifty-five gallon drum and shall contain no sharp edges, either on the inside or the outside. Each shall be painted so that it is easily distinguished from the background. A protective device around the top of the barrels is permitted.

4. Management shall designate the order in which the entries shall compete. Not more than one horse shall be in the ring at one time except for a back up horse.

5. A rider shall be considered "on course" once any part of the horse crosses the starting line until every part of the horse crosses the finish line after completing the course.

6. Timing Line - The course for all competitors shall include a timing line to be a distance of at least 20' from the first obstacle. The timing line is imaginary and should be indicated by stakes, pylons, or other suitable markers.

7. Start and Finish - The rider shall be signaled when the judge and timing officials are ready. At anytime within one minute after the ready signal is given, the entry shall cross the timing line and begin the course. Starting and finishing time shall be taken the instant any part of the horse crosses the timing line. Running start is prohibited. The horse must come to a halt after finishing the course before leaving the arena, but may make one circle before coming to a halt.

8. Ties to be broken with a runoff or by flip of coin if agreed to by contestants.

9. Penalties - Any of the following infractions shall disqualify an entry:

a. Failure to begin course within one minute after ready signal.

b. Any deviation from the pattern is cause for disqualification.

c. Fall of horse and/or rider while on course.

d. Spurring, striking or beating the horse in any manner whatsoever forward of the front cinch, after entering the arena. (Touching the horse shall not be considered striking or beating the horse.).

e. Horse being unruly or out of control.

f. Any kind of cruelty to the horse, whether or not specifically mentioned in this rule.

g. Excessive use of spurs, crop, bat or romal.

h. A five-second penalty shall be assessed for each obstacle knocked down, unless otherwise provided in

the class specifications. The competitor must remain on course as if the obstacle were still standing.

i. Failure of entry to leave the ring immediately upon notification by the judge of disqualification shall bar both the horse and rider from further participation in the show.

10. Breakage - If tack or equipment should break or the horse should cast a shoe while negotiating the course, and the difficulty prevents completion of the course, the entry shall be disqualified. Should the entry be able to continue the course despite the difficulty and without cruelty to the horse, he may continue without penalty.

11. The method of holding reins is optional.

12. Timing - A photo electrically activated electronic or electric timer is preferred to stop watches. If such an electrical timer is used, at least one official should take the time with a stop watch in case of failure of the electric device. If such an electrical timer is not available, three stop watches are recommended to be used, with the median time being the official time. (The median time is the time indicated by two of the three stop watches if two agree. If no two watches agree, the median time is the time indicated by the watch which indicated neither the fastest nor slowest time.) All stop watches must be calibrated in at least tenths of a second.

13. All measurements given in gymkhana rules are desired if arena space allows. However, when space does not allow prescribed measurements, common sense must prevail for safety reasons.

B. Appointments

1. Equipment and attire must be western.

a. Hats or safety helmets are recommended for all gymkhana classes, but are at the exhibitor's option. If hat or safety helmet is worn and it falls off and touches the ground while in the arena, a five (5) second penalty will be assessed.

b. McClellan or similar saddle shall be considered western when western bridles are used.

c. All western tack and equipment is acceptable if humane. If a tiedown is used the noseband must be rope, leather, or nylon. No wire permitted.

2. The following items of equipment are prohibited in all classes in this division:

a. Any other kind of bridle or equipment not appropriate to the saddle being used and to the attire of the rider.

b. Unusual construction or arrangements, if considered by the judge to be inhumane, abnormal or dangerous.

C. Cloverleaf Barrel Competition

1. Three competitions are available, known as Table 1, Table 2 and Table 3.

2. Regardless of which table is being used, the rider shall have the option of riding either course "A" or course "B".

a. Course "A" - The entry shall cross the timing line, circle barrel 1 clockwise, circle barrel 2 counter-clockwise, circle barrel 3 counterclockwise, and cross timing line.

b. Course "B" - The entry shall cross timing line, circle barrel 2 counter-clockwise, circle barrel 1 clockwise, circle barrel 3 clockwise, and cross timing line.

3. Table 1 - Three barrels shall be placed to form an equilateral triangle with sides of 75' each, with barrels 1 and 2 each 30' from the starting line. The length of the timing line shall be 75'.

4. Table 2 - Three barrels shall be placed to form an isosceles triangle. The distance from barrel 1 to barrel 2 shall be 90'. The distance from barrel 1 to barrel 3 shall be 105'. The distance from barrel 2 to barrel 3 shall be 105'. The distance from barrels 1 and 2 to the timing line shall be 60'. The length of the timing line shall be 90'.

5. Table 3 - Three barrels shall be placed to form an isosceles triangle. The distance from barrel 1 to barrel 2 shall be 105'. The distance from barrel 1 to barrel 3 shall be 120'. The distance from barrel 2 to barrel 3 shall be 120'. The distance from barrels 1 and 2 to the timing line shall be 75'. The length of the timing line shall be 105'.

D. Pole Bending Competition

1. The rider shall have their choice of the side on which to pass the first pole.

Management should allow ample room between all running lanes and between the lanes and walls or fences.

2. Six poles shall be placed 21' apart in a straight line down the approximate center of the ring, with the first pole being 21' from the timing line. The timing line shall be 30' long. The entry shall cross the timing line, move in an approximately straight line to pole 6 (farthest pole), make a 180° turn around pole 6, pass between pole 6 and pole 5, bend through the poles to pole 1, circle pole 1, bend through the poles to pole 6, make a 180° turn around pole 6, and cross the timing line, by moving along the poles on the side opposite that on which it first approached pole 6.

E. Keyhole Competition

1. The course shall be laid out with a limed keyhole on the ground, with the throat of the keyhole perpendicular to and facing the timing line, and the center of the circle of the keyhole one hundred feet from the timing line. The keyhole shall be in the form of a broken circle 20' in diameter, with a throat 4'

wide, inside white lines, and 10' long. The horse shall cross the timing line, enter the circle of the keyhole, turn around in either direction, entirely within the circle of the keyhole, and recross the timing line. The entry is disqualified if the horse steps on or over the limed keyhole boundary at any point or if the horse turns around in the throat of the keyhole rather than in the circle. The area surrounding the limed line shall be raked or swept after each ride. Walking or trotting prior to entering the key shall result in disqualification.

F. Flag Race Competition

1. Three competitions are available, known as Table 1, Table 2 and Table 3. Management should allow ample room between the barrels and any side fences. Measurements are made to the center of the base of the barrel. A five gallon bucket 3/4 full of sand or other suitable material, shall be placed on the barrels as a depository for the 18" flags.

2. Regardless of which table is being used, the rider shall have the option of riding either course "A" or course "B".

a. Course "A" - The entry shall cross the timing line, and begin the course by following the pattern to the left.

b. Course "B" - The entry shall cross the timing line, and begin the course by following the pattern to the right.

3. Penalties - Knocking over the bucket holding the flags without knocking it off the barrel incurs a five-second penalty..

4. Causes for disqualification.

a. Failure to pick up the flag on the first pass.

b. Failure to place the flag in the bucket on the first pass.

c. Touching any part of the horse's body with the flag or stick.

d. Dropping the flag.

e. Knocking over any of the barrels, or knocking the bucket off the barrel.

5. Table 1 - Three barrels shall be placed to form an isosceles triangle. The distance from barrels 1 to 2 and 2 to 3 shall be 100'. The distance across the base of the triangle shall be 75'. The distance from the base of the starting line shall be 75'. The timing line shall be 75' in length.

6. Table 2 - Three barrels shall be placed to form an isosceles triangle. The distance from barrels 1 and 2 and 3 shall be 120'. The distance from barrels 2 and 3 shall be 30'. The distance from the timing line to barrel 1 shall be 50'. The timing line shall be 50' in length.

7. Table 3 - Three barrels shall be placed to form an isosceles triangle. The distances shall conform to any of the tables in the Flag Race or Cloverleaf

Competition patterns. Riders may have the option of riding course "A" or course "B".

G. Stake Race

1. MARKERS: The start and finish line is 20 feet wide and marked by two upright markers, ten feet on each side of the center line and short enough so as to not interfere with the timer, if one is used. Short pylons or cones are recommended. The first and second poles marking the center line are each 40 feet from the start and finish line, making them a total of 80 feet apart.

2. START: Start by crossing the start and finish line between the two upright pylons or cones. Run a figure eight (8) around the upright poles marking the center line, and finish by again crossing the start and finish line between the pylons and cones and closing the eight (8).

3. CLASS PROCEDURE: At the first pole, the contestant may go right or left, just so the figure eight (8) is run.

4. NO TIME: If the figure eight (8) is not completed, or if the upright marker is knocked down, there is no time.

Flag Race Competition

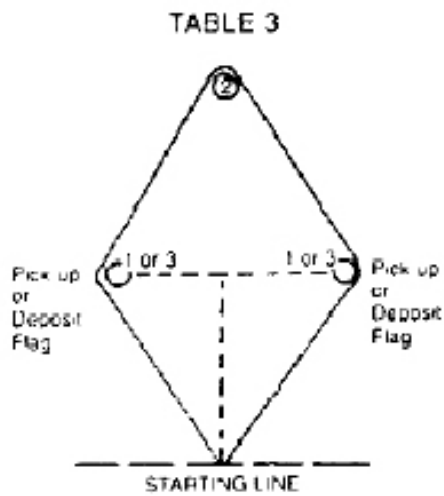
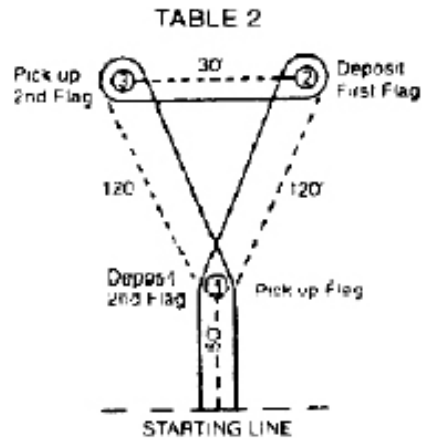
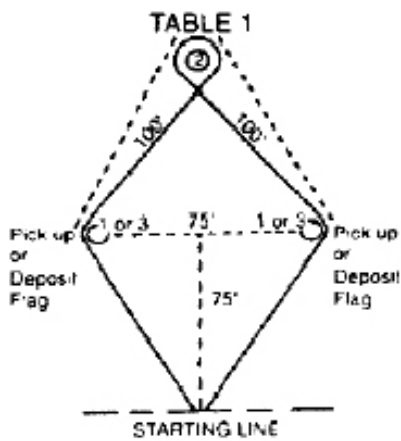

Cloverleaf Barrel Racing Pattern

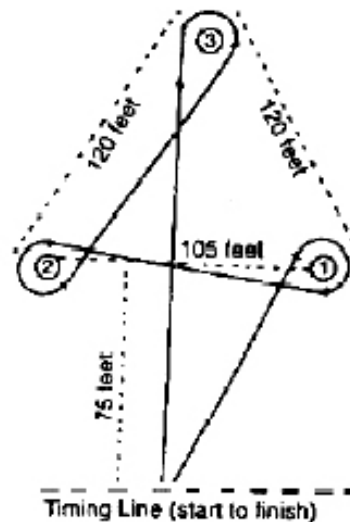

Stake Race Pattern

Pole Bending Pattern

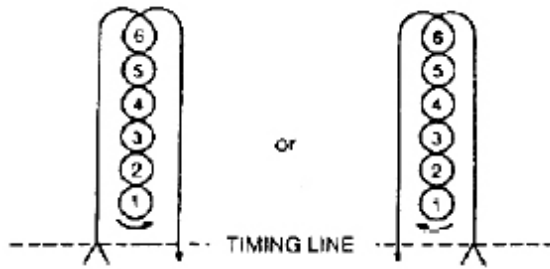

Keyhole Pattern

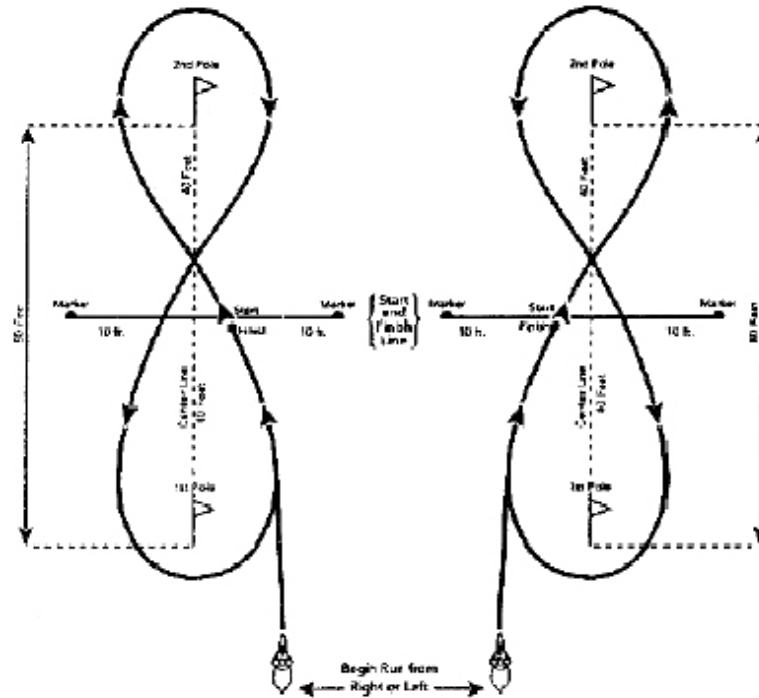
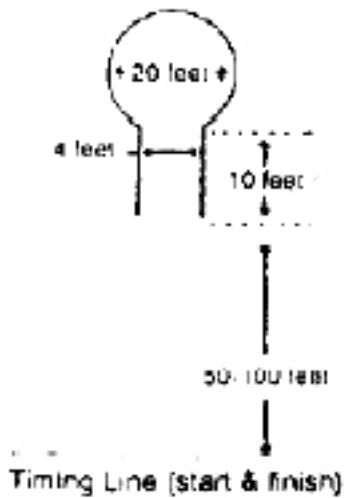

RULE 78

Disciplined Rail Horse or Pony

A. General

1. This class is to show the ability of a highly trained Western or English horse. Appointments shall follow those of pleasure horse classes.
2. Judge shall work the Quarabs adequately but must not overwork the entries. This is not a game or a fault and out class, and shall not be judged on an elimination basis. Final judging shall be on the basis of the best overall disciplined rail performance. At all times, the safety of the horses and exhibitors to be the first concern.
3. Disciplined Rail Horse classes must be restricted to either Western or English equipment. No points will be awarded to mixed seat classes.

B. Disciplined Rail Horse, Western Equipment

1. The class routine shall be to perform work on the rail, and may include, but is not limited to:
 - a. A short walk, jog or slow lope.
 - b. A hand gallop (no more than eight horses at a time, twice around the ring).
 - c. Flying changes of lead each way of the ring.
 - d. Starting into a lope from a halt.
 - e. Sliding stop.
 - f. Starting and traveling on the incorrect lead.
 - g. Side pass both left and right (once each way).

- h.** Turn on forehand and turn on hind quarter (once each way).
- i.** Dismount and mount from either side.
- j.** Stand quietly.
- k.** Judge may ask for additional safe work.
- 2.** To be judged on performance, manners and conformation.

C. Disciplined Rail Horse, English Equipment

- 1.** Entries may be shown either Hunter Seat or Saddle Seat. The class routine shall be to perform work on the rail, and may include, but is not limited to:
 - a.** A short walk, trot, extended or strong trot, or canter.
 - b.** A hand gallop (no more than eight horses at a time).
 - c.** Simple changes of lead each way of the ring (not more than twice for each lead).
 - d.** Starting into a canter from a halt.
 - e.** Square stop.
 - f.** Starting and traveling on the incorrect lead (counter canter).
 - g.** Leg-yield both left and right on the rail and/or on the diagonal (once each way).
 - h.** Turn on forehand and/or haunches (once each way).
 - i.** Shoulder-in and/or haunches-in and/or out at a walk and/or trot (once each way for each movement).
 - j.** Stand quietly.
 - k.** Working of entrants “on the buckles” or without contact of the reins is limited to the walk only. Any other movements will not be asked to be performed except with light contact. Riding “on the buckles” will not be considered riding with light contact.
- 1.** Judge may ask for additional safe work.
- 2.** To be judged on performance, manners and conformation.

RULE 79

Driving

A. General Appointments

- 1.** The equipment required for all driving classes shall include a whip, collar, or breast collar with standard driving bridle. Appropriate bits, including leverage bits, may be used. Overcheck or side checks permitted at the option of exhibitors. To be shown in appropriate 2 or 4 wheel vehicle suitable to the Quarab. Breeching or thimbles may be used at the option of the exhibitor.
- 2.** Horses shall be serviceably sound and shown without artificial appliances (i.e., wired ears).
- 3.** Attire - Exhibitors shall be suitably attired for the type of vehicle they are driving. Drivers may use lap robes. Roadster colors are prohibited.

- 4.** One passenger permitted. Any assistance to the driver will result in disqualification.

B. Pleasure Driving (2- or 4-wheel vehicles)

- 1.** Entries should give the appearance of being a pleasurable driving Quarab. To enter the ring at a normal trot.
- 2.** Boots or bandages are prohibited.
- 3.** To be shown at a flat-footed walk, a normal trot and a strong trot, both ways of the ring. Extreme speed to be penalized. To stand quietly and back readily. All gaits to be performed both ways of the ring in a smooth, relaxed, balanced manner, consistent with conformation type of animal. Straight & Pleasure type will move with rounded, medium strides, flexed neck with poll higher than withers, and will display forward reach and flexion of knees and hocks. Stock types may move with lower strides, with less flexion of knees and hocks. Faults would include stiff or choppy gaits; inconsistent rhythm, crooked or sideways movement. A tendency to move in a western style jog instead of a normal trot should be penalized. All animals moving in an extremely slow jog instead of a normal trot must be penalized.
 - a.** Walk: Flat-footed, free, rhythmical four beat gait.
 - b.** Normal Trot: Balanced, free moving and relaxed two beat gait.
 - c.** Strong Trot: Balanced lengthening of stride with noticeable difference from normal trot, without excessive speed, loss of form, or two beat gait.
- 4.** To be judged on manners, quality, performance, conformation and suitability.

C. Fine Harness (4-wheel vehicles only)

- 1.** Entries to give a performance showing style, presence, finish and cadence. To enter the ring at a park trot.
- 2.** Quarter boots or rubber bell boots are permitted.
- 3.** Horses may be unchecked while lined up. Attendant may stand an entry on its feet and thereafter, he/she shall remain at least two paces distant from the head.
- 4.** All gaits to be performed both ways of the ring and are to be collected and balanced, with high action, brilliance and presence. High head carriage and great elevation of knees and hocks are normal. Knee flexion should be proportionate to hock flexion. The animal's energy should be directed toward animation rather than speed. Faults would include stiff or choppy gaits; dragging hocks; unbalanced action; crooked or sideways movement.
 - a.** Walk: Collected, animated, brisk, with four beats.
 - b.** Park Trot: Animated, balanced two beat gait with cadence.

5. To be shown at a walk (need not be flat-footed) and park trot, both ways of the ring. Extreme speed to be penalized.
6. To be judged on performance, manners, quality, conformation and suitability.
7. Horses not to back.
8. Four-wheeled cart only.

D. Ideal Quarab Driving

This class displays the balance required of a Pleasure driving Quarab which also exhibits good conformation.

1. To be shown in an appropriate two or four-wheel cart, giving the appearance of being a pleasurable driving Quarab. To enter the ring at a normal trot. To be shown at a flat-footed walk, a normal trot, and a strong trot, both ways of the ring. Extreme speed to be penalized. Entries to stand quietly and back readily.
2. All Quarabs to be stripped and judged on conformation. In addition to exhibitor, one or two attendants per Quarab are permitted in the ring for stripping/grooming and should enter immediately upon being signaled by judge to do so. Animals are not to be re-harnessed. They may be shown in hand, with headstall or halter, without being penalized. Handler and driver must be the same. Time limit for stripping/grooming is two minutes.
3. To be judged 50% on performance and manners, 25% on conformation, and 25% on markings.

E. Obstacle Driving

1. Animals are required to work over and through obstacles.
2. The Show Committee and/or course designer must keep in mind that the course must accommodate suitable two or four-wheel vehicles. Animals in the obstacle driving class must not be asked to jump over any obstacles, but may be asked to drive over flat obstacles. Obstacles should simulate conditions normally encountered on a pleasant afternoon drive.
3. This is not a timed event and the speed with which the course is completed should not be used in whole or in part to determine placing.
4. Suggested obstacles unique to driving:
 - a. Positioning one wheel (rear wheel if four-wheel vehicle) within a 24" minimum circle, pivot the Quarab 360° in either direction, maintaining the position of the wheel within the circle.
 - b. Back the Quarab until an obstacle is bumped. Dislodging a "jump" could be used to evidence sufficient backing.
 - c. Drive in a straight line, keeping one wheel between a 12" minimum designated strip.

- d. Drive over a flat obstacle such as water, flat plywood, or firmly anchored tarp.
- e. Mount or dismount from either side of vehicle.
- f. Carry objects in the vehicle.

Variation on class - Gambler's Choice Obstacle Driving. To be

conducted as outlined above, with the following additions:

- (1) Each obstacle is to be assigned a point value by the course designer. The course will include a start/finish line for the purpose of timing.
 - (2) The obstacles are to be completed at the discretion of the driver, in any direction, in any order, within a time period, such as two minutes, as designated by the Show Committee. Placing for the class will be determined by the total points accumulated within the time period allowed.
 - (3) Ties will be broken by deducting points for the amount of time taken to return to the finish line after the time period is announced as being over by such method as a whistle.
 - (4) The amount of times a particular obstacle may be repeated will be determined by the course designer, but no obstacle may be repeated until one or more other obstacles have been completed.
- g. Half circle serpentine-Trot through cones.

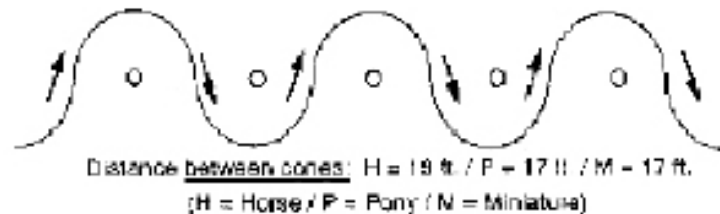

- h. Deviation serpentine – Trot through cones.

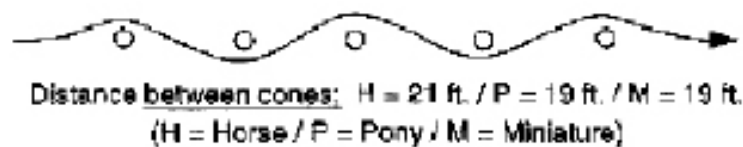

- i. Drive through U.

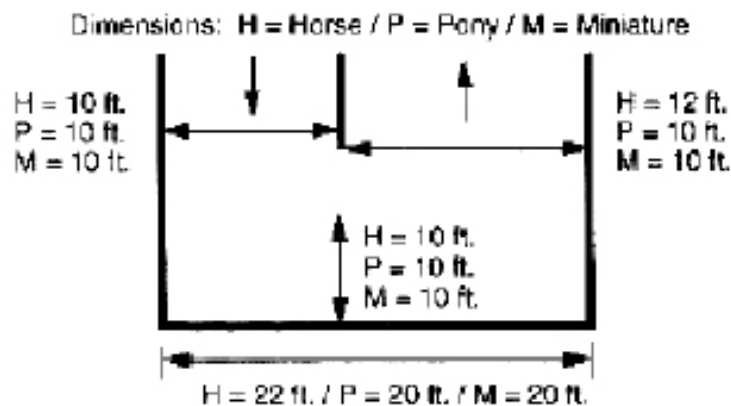

Dimensions are for walk through, for Trot thru add 2" to all dimensions.

j. Offset gates - Trot through first gate. Then, still at a trot, circle back behind first gate and around and through next gate.

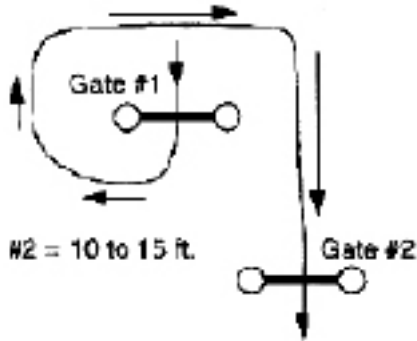

Gate width = 58"

Distance from gate #1 to gate #2 = 10 to 15 ft.

I. Disciplined Rail Driving

1. This class is to show the ability of a highly trained Quarab. Appointments shall follow those of Pleasure driving classes.

2. To be shown in a two-wheeled cart.

3. Judge shall work the Quarabs adequately, but must not overwork the entries. This is not a game or a fault-and-out class and shall not be judged on an elimination basis. Final judging shall be on the basis of the best overall disciplined rail performance.

4. This class routine shall be to perform work on the rail and will include, but not be limited to:

a. A flat-footed walk, normal trot.

b. A strong trot (not to exceed twice around the ring).

c. Starting with a flat-footed walk, through a normal trot to a strong trot.

d. Stand quietly.

e. Pivot (Quarab to side pass as though there were a wall in front and behind with one wheel rolling). Pivot not to exceed 90% (Judge may ask for both right and left or either.).

f. Dismount from the cart and remount (No headers to be used and reins to be held at all times).

5. To be judged 75% on performance, 25% on manners and conformation.

J. Combined Driving

Combined Driving event includes three competitions held over a two or three day period that include Dressage, Cross County Marathon, and an Obstacle course.

1. Generala. Governing bodies for Combined Driving are ADS, USA Equestrian formerly known as the AHSA, and FEI for the international competition.

b. Complete rules for CDE can be found in the ADS Handbook and the USA Equestrian rule book.

2. Definitions

a. A CDE usually held over a two or three day period and has three competitions. The whip drives the same animal or animals throughout the competitions.

(1) Presentation

(2) Dressage competition

(3) Cross country marathon (Three Sections A, B & E)

(4) Obstacle course

b. Driving Trials has three competitions held over a one or two day period. The whip drives the same animal or animals throughout each competition.

(1) Dressage

(2) Cross country marathon (Section E only)

(3) Obstacle course

3. Points

a. No points will be separated from a Combined Driving Event score and applied to any other IQHA ROM point earning event (i.e. Dressage, obstacles ROM)

b. Individual placings in non ADS or USA Equestrian Combined Driving Events will receive points based on the regular IQHA point scale times the number of days of the competition

RULE 80

Costume

Costume classes are not ROM pointed classes. Refer to rules in World Show Premium Book.

RULE 81

Ideal Quarab

This class displays the balance required of a pleasure horse which also exhibits good conformation.

Animals to be stripped and judged on conformation and markings. Two attendants per Quarab are permitted in the ring for stripping and grooming.

Wheel barrows, carts or any type of mechanical apparatus is prohibited in the ring.

A. Western

To be shown at a walk, jog, and lope, both ways of the ring on a reasonably loose rein, without undue restraint. Animals are required to back. To be judged 50% on performance and manners & 50% on Conformation.

B. English

To be shown at a walk, normal trot, and canter, both ways of the ring. Extended trot may be required, at the judge's discretion. May be asked to back. Entries are required to walk prior to execution of canter and reverse. To be judged 50% on performance and manners, & 50% on conformation.

At such time as the youth membership shall reach viable numbers to support a youth organization, the following framework has been written to allow its active formation.

RULE 82

Youth Organization Constitution

Article I. Name

This sub-organization shall be named The International Quarab Horse Association Youth Division. The official abbreviation shall be IQHAYD. This organization is subject to the directives and rules established by the International Quarab Horse Association, Inc.

Article II. Purpose

The purpose of this non-profit organization will be to promote and encourage the youth members of the The International Quarab Horse Association, Inc. on a state and national level, and to promote the general interest of youth and the Quarab horse.

Article III. Membership

Membership will consist of all those who are youth members of IQHA. Dues must be paid for the current year to IQHA and each member must be in good standing. Voting rights in the Youth Organization are to be one (1) vote per youth member, limited to IQHAYD matters only.

Article IV. Officers

The officers of this organization must be in good standing with IQHA and IQHAYD. The Youth Organization Executive Board will consist of the President, Vice-President, Secretary, and Treasurer, as elected by the membership. The officers, after routine nomination, will be elected at the annual youth meeting. The person receiving the majority of voted will be elected. No absentee ballots are allowed. There will be no written or verbal nominations made for an absent member. Only members present at the meeting may vote. Voting privileges are restricted to members in good standing with IQHAYD. No office may be held by the same individual for more than two (2) consecutive years.

Article V. Amendments

Any proposed amendment to this Constitution must be submitted in writing and signed by five (5) youth members. Before acceptance of any proposed amendment, it must be read at the meeting. Discussion must follow. A vote may then be taken. The amendment, as voted on, must then be submitted to IQHA for approval. It will become part of this Constitution upon approval by two-thirds of the IQHA Board of Directors.

Article VI. Voting Privileges

Each youth member has one (1) vote. Only members in attendance at the IQHA meeting have a voting right. Voting members must be in good standing with

the IQHA and IQHAYD. No absentee ballots are permitted in any election.

Youth Organization Bylaws

Article I. Election of Officers

The officers will be the President, Vice-President, Secretary, and Treasurer, and are elected at the IQHAYD annual meeting. Each officer will be elected by a majority vote after proper nomination. Nomination procedure is as follows:

1. Nomination to be made by a youth member present.
2. Nomination must be accepted by person nominated.
3. Nomination is voted on by youth members present at meeting.
4. Nominee elected takes office.

The term of office will be for one year and no office may be held for more than two (2) consecutive years by the same individual. Should any vacancy occur, the President of IQHAYD shall appoint a replacement. The input of the current Youth Advisor and Zone Advisors will be considered.

Article II. Duties of Officers

The President shall preside over all meetings, exercise general supervision and management, subject to the approval of the youth members. The president will vote only to break a tie.

The Vice-President shall preside over any meeting in the absence of the President.

The Secretary shall keep minutes of any meetings and maintain a list of youth members, showing names, addresses, and positions held in the organization. In addition, the Secretary is to submit a copy of the membership list to the IQHA business office for permanent record, keep all records of the organization, including financial reports and routine business records, notify the Executive Board of any special meetings, notify the membership of any special activities. As required, the Secretary shall also read minutes or correspondence to organization membership.

The Treasurer shall present records of all checks written and moneys received, read the current treasurer's report at each meeting. All funds will be handled at the IQHA business office in a special youth account. These funds must be generated by projects conducted by the IQHAYD outside the IQHA, and will fund IQHAYD special projects.

Article III. Duties of Youth Members

Duties of youth membership is to be the policy making body of the youth organization and to act on all important matters brought before the organization, to elect the Youth Executive Committee, and to vote on an individual basis, as he or she feels benefits the youth on a national level.

Article IV. Material of the Organization

All officers and committee heads shall turn over to their successors all information pertaining to the organization.

Article V. Meetings

There shall be no less than one (1) regular meeting of the youth organization each year. Any special meetings may be called by the President at a central location. The membership shall be notified by mail or through The Quarab Quarterly newsletter. Meeting notification shall be at least two (2) weeks prior to the meeting.

Article VI. Quorum

A minimum of twenty (20) members in good standing must be present and voting at a meeting in order to constitute a quorum for the transaction of business.

Article VII. Order of Business

1. Meeting called to order.
2. Roll call.
3. Reading of the Minutes of the previous meeting.
4. Treasurer's report.
5. Reading of communications.
6. Unfinished business.
7. Election of officers.
8. New business.
9. Adjournment.
10. Program.

Article VIII. Amendments

Any amendment to these Bylaws must be presented at the meeting in writing, signed by five (5) youth members. Discussion must follow. A vote may then be taken. The amendment must then be submitted to IQHA for approval. It will become part of this Constitution upon approval by two-thirds of the IQHA Board of Directors.

Article IX. Annual Dues

No dues are to be assessed by the IQHAYD for membership in the organization. Members must be current year members in good standing of the IQHA.

Article X. Termination of IQHAYD

Should the IQHAYD disband, the Secretary shall turn over all records to the IQHA. All records shall be kept for a period of one (1) year. All moneys will be placed in a separate savings account for a period of one (1) year. If, at the end of that time, there is no interest in resuming the IQHAYD, all moneys will be considered the property of IQHA.

Article XI.

Any actions taken by the IQHAYD must meet with the approval of a majority of the IQHA Youth Committee and the IQHA Board of Directors. The IQHA Board of Directors' authority supersedes both the Youth Committee and the IQHAYD.

Youth Organization Rules

A. Age Requirements

1. Youth Activities classes and events are open to persons 18 years of age and younger.
2. The age of the youth on January 1st shall be maintained throughout the year. Persons born on January 1st shall assume the greater age on that date.
3. Married and/or divorced contestants, regardless of age, are not eligible to participate in the YA program.
4. IQHA may require that a copy of a birth certificate be submitted to verify the age eligibility of a youth.

B. Divisions

1. Youth classes may be divided by age of youth on the following basis:
 - a. 8 and Under
 - b. 13 and Under; 14 through 18
 - c. 10 and Under; 11 through 13; 14 through 18
 - d. Age groups may be combined when there are insufficient entries for points in one of the age groups.
2. When divided into two or more age groups, no horse shall compete in more than one age section of the same class (i.e., the same Quarab may not be used in both the 13 and Under and the 14 through 18 classes of YA Western Pleasure at one show.). This rule does not apply to showmanship and equitation classes where the handler or rider only is being judged. Youth halter classes may be held and divided at the Show Committee's discretion.

C. Stallions

1. No stallions or colts are permitted in youth activities events.

D. Combined

In no case may Western and English styles of showing be combined, except in Trail, Side Saddle, AM and YA Novice Walk/Trot, AM and YA Novice Showmanship, and YA Leadline and Walk/Trot. Western and English Showmanship classes, Western and English Pleasure classes, Western and English Equitation classes, etc. may not be combined at any time. No points will be awarded to such combined events.

E. Halter

1. YA classes at halter may be offered. (i.e., YA Geldings, YA Mares) This may be divided by age and/or type.

F. Designated

1. To be eligible for YA points, all classes must be designated by "YA" before the class title.

G. Approved Classes

1. In addition to regular performance division events, additional classes are included in the youth program as noted.

2. The youth program is for competition in Quarab approved classes and shows. No open points shall be counted except in special cases approved by the Youth Department (i.e., Competitive Riding).

3. Any class listed in the regular performance division of this rule book may be written as a youth activity class. Classes will follow the same appointments, requirements and judging specifications as the open division.

4. For Showmanship and Equitation class rules, refer to Rules 86 and 87, respectively.

I. Payback in YA Classes

1. Shows may pay back YA halter and pleasure classes.

2. Shows may not pay back YA Equitation or Showmanship classes (Youth being judged, not horse).

3. Weekend high-point awards may be paid to the youth horse only, not the individual.

4. IQHA youth members may accept class payback and cash high-point awards for their horses without jeopardizing their IQHA youth status.

Individuals are encouraged to check with any other organizations with which they may be involved for clarification on how this rule effects their Amateur status in that organization.

J. Walk/Trot Equitation — English or Western (11 and under)

YA Walk/Trot is not an ROM-approved class. It is an entry level class and any youth, member or non member, may show any horse/pony in this class. Contestants in this class may not cross enter into **YA Lead-Line** or any other class at same show that requires a canter or lope. IQHA will issue to owners of all horses used in YA Walk/ Trot classes year end certificates in the name(s) of youth exhibitor(s). Equipment and attire may be English or Western.

K. YA Leadline — English and Western (8 and under)

YA Leadline is not an ROM-approved class. It is an entry level class and any youth, member or non member, may show any horse/pony in this class. Contestants in this class may not cross enter into **YA Walk-Trot** or any other class at the same show that requires a canter or lope. IQHA will issue to owners of all horses used in YA Leadline classes year end certificates in the name(s) of youth exhibitor(s).

Equipment and attire may be English or Western. Any handler leading a Quarab in this class must be 14 year of age or older.

L. YA Novice Walk/Trot and Showmanship

1. Open to any IQHA Youth under the age of 19 who is a member in good standing and has not earned more than 35 total IQHA ROM points except halter.

2. For further rules regarding YA Novice Walk/Trot and Showmanship, refer to Amateur Division Novice Walk/Trot and Showmanship, Rule 83.G.-H.

M. Youth Organization Liaison

The IQHA President shall appoint a liaison on the Executive Committee representing the Youth Program.

RULE 83

Youth/Amateur Projects

A. General

1. Amateur & Youth projects are non-riding activities in which all amateurs and youths who are current members of IQHA (amateurs must also be a current amateur member) may participate. Projects are judged at the World Championship Show. IQHA is not responsible for any damage or loss of projects before, during or after the judging.

2. Amateur & Youth Projects Competition is held at the World Championship Show. Contact the IQHA office, World Show Premium Book, or IQHA web site for details and rules.

RULE 84

Youth/Amateur Team Tournament Competitions

Team Tournament competition is held at the World Show. Contact the IQHA office, World Show Premium Book, or IQHA web site for details and rules.

Team tournaments may be held at any show.

At such time as the amateur membership shall reach viable numbers to support an amateur organization, the following framework has been written to allow its active formation.

RULE 85

Amateur Association Division

Constitution

Article I. Name

This organization shall be named the International Quarab Horse Association Amateur Association. This organization is subject to the directives of the International Quarab Horse Association, Inc.

Article II. Purpose

The purpose of this non-profit organization will be to encourage Amateur members of the International Quarab Horse Association, Inc. to promote the general interest of the Amateur and the Quarab horse.

Article III. Membership

Membership will consist of all those who have paid their annual International Quarab Horse Association membership dues and annual Amateur fee. Amateur members shall elect an Amateur Association Board and an Amateur Association Executive Board.

Article IV. Officers

The officers of this organization must be members in good standing of the International Quarab Horse Association. The Amateur Association Executive Board shall consist of President, Vice President, Secretary, Treasurer, and the immediate Past President. The Amateur Association Board shall consist of the Amateur Executive Board and four (4) at-large board members (elected by Amateurs in good standing by mail-in ballots) and the Amateur Committee Chairperson to Breed Council (appointed position).

To be nominated to any Amateur Association Board position, an individual must hold a IQHA Amateur card during the current and previous calendar years in which he/she is nominated and must be a member in good standing of IQHA.

Article V. Amendments

Any proposed amendments to this Constitution must be submitted in writing and signed by five (5) Amateur members in good standing. Before acceptance, any proposed amendment must be published in the official publication of the International Quarab Horse Association and presented at an Amateur Association general membership meeting. After such notice, it will become part of the Constitution upon approval by two-thirds of the voters present and approval by the IQHA Board of Directors.

Article VI. Voting Privileges

Each Amateur member in good standing has one (1) vote.

Amateur Association Bylaws

Article I. Election of Officers

Ballots to nominate officers shall be published in the August issue of The Quarab Quarterly newsletter in the year election is to be held. Election to the Amateur Association Board shall take place in December, with ballots to be received at a location designated by the Quarab business office. The four at-large board members will serve staggered terms, with two being elected in odd numbered years and two being elected in even numbered years. In the event of a tie vote for an at-large position, the Amateur

Association Board will break the tie. In the event of a tie vote for President, Vice President, Secretary, or Treasurer, a mail-in run-off ballot will be sent to all Amateurs in good standing. To be eligible for nomination for Amateur President or Vice President, nominees must be current members of the Amateur Association Board. The term for all newly elected Amateur Board members (officers and non-officers) shall begin upon completion of the Annual Quarab Convention following the election.

A. At-large vacancies on the Amateur Association Board will be filled by appointees of the Amateur Association President with approval of the Amateur Association Board. Appointees are not required to be current members of the Amateur Association Board, but must be IQHA Amateur members in good standing during the current and previous calendar years.

B. When a replacement is needed for an Amateur Association officer, other than President, the Amateur Association Board will nominate and vote on the replacement, who will serve the remainder of the vacant term. With the exception of the Vice President, this replacement is not required to be a current Amateur Association Board member, but must be a IQHA Amateur member in good standing during the current and previous calendar years.

C. To be nominated to any Amateur Association Board position, prior to the closing date for receiving nominations, an individual must:

- 1.** hold a current IQHA membership and IQHA Amateur card;
- 2.** have been a IQHA member and IQHA Amateur member the previous year;
- 3.** have paid the following year's IQHA membership and Amateur dues.

D. Any Amateur Association Board member (officer or non-officer) who does not fulfill their responsibilities or attendance requirements is subject to removal from their position. A majority poll of the Amateur Association Board shall constitute reason to refer the request for removal to the IQHA Executive Board for a final decision. All replacements for the position will be selected according to the Amateur Association Bylaws, Article I.A. and I.B.

E. Any person removed from the Amateur Association Board for any reason is not eligible to be nominated for any Amateur Association position for a period of no less than three full calendar years from the time of removal. A calendar year is defined as January 1 through December 31.

Article II. Duties of Officers

The President may be elected for any number of terms, but may serve no more than two (2) consecutively. He or she shall:

1. preside over all meetings and exercise general supervision and management;
2. vote only to break a tie;
3. have a seat on the National Board of Directors (Sector 43);
4. be an ex-officio member of all committees;
5. chair the Amateur Association Eligibility Review Board;

The Vice President shall:

1. assume the duties and responsibilities of the President in their absence
2. serve as a member of the Amateur Association Eligibility Review Board;

The Secretary shall:

1. send notices of upcoming Amateur meetings;
2. record minutes of all Amateur meetings and disperse them to the appropriate parties;
3. maintain a file of minutes and records;
4. have past minutes available at all meetings;
5. send necessary Association correspondence, including letters and news releases;
6. keep a membership roll of attendees at all meetings;
7. preside over meetings in the absence of the President and Vice President;
8. serve as a member of the Amateur Association Eligibility Review Board;
9. perform other duties as requested by the President.
10. keep an accurate, updated record of Amateur rule additions, changes or deletions so they can be given to the appropriate person when a new Rule Book is to be printed.

The Treasurer shall:

1. keep records of Association funds;
2. read treasurer's reports at Amateur Association meetings;
3. serve as a member of the Amateur Association Eligibility Review Board.

The Immediate Past President shall:

1. sit on the Amateur Association Executive Board and have full voting powers and privileges;
2. serve as a member of the Amateur Association Eligibility Review Board;
3. hold a position on the IQHA Executive Board.

Article III. Duties of Amateur Association Board

Amateur Association Board members shall promote the Amateur to the best of their ability and be the policy making body of the Amateur Association. The Amateur Association Board shall consist of the Amateur Executive Board, Amateur Committee Chairperson to the Breed Council, and four (4) at-large members.

A. Amateur Committee Chairperson to the Breed Council shall:

1. be appointed to a two (2) year term by the IQHA President;

2. be a member of the Amateur Association Board with full voting powers and privileges;
3. be mandated under the attendance and performance rules of the Amateur Association;
4. chair the Amateur Committee meeting at Convention and represent the Amateur Committee members at the Breed Council sessions.

B. Amateur Eligibility Review Board shall:

1. consist of the Amateur Association Executive Board;
2. review complaints filed against Amateurs, gather data, and refer its recommendations to the IQHA Executive Board for a final decision.

C. Attendance Policy of the Amateur Association Board.

There shall be at least three (3) Amateur Association Board meetings per year, one each held at: IQHA Convention, IQHA World Show, and a Fall meeting held in conjunction with the IQHA Executive Board Fall meeting. Of those meetings, officers (President, Vice President, Secretary, Treasurer, and Immediate Past President) must attend the Convention meeting plus at least one of the remaining two meetings, with attendance recommended at all three meetings. Non-officers (At-large Board members and Amateur Committee Chairperson to Breed Council) must attend the Convention meeting, with attendance highly recommended at the other two meetings. In the event of an absence, notification must be made in writing to the Amateur Association President within one (1) week prior or, in the event of extenuating circumstances, one (1) week after the meeting. The Amateur Association Board will review all excessive absences.

Article IV. Quorum

At meetings of the Amateur Association Board, a quorum shall consist of a consensus of four (4) voting members. In the absence of voting members present, a telephone poll of all absent Amateur Board members will be conducted to determine if a quorum can be reached.

At the Amateur Committee meetings at the annual Convention, the majority present shall rule.

Article V. Order of Business

1. Meeting called to order.
2. Roll call.
3. Reading of the Minutes of the previous meeting.
4. Treasurer's report.
5. Reading of communications.
6. Unfinished business.
7. New business.
8. Adjournment.

Article VI. Amendments

Any amendment to the Bylaws must be presented in writing at a meeting. It shall be published in the official publication of the Quarab Horse Association

and voted on at the next general membership meeting and approved by the IQHA Board of Directors.

Article VII. Annual Dues

Dues to be paid by January 1 of each calendar year. Amateur Association Board members and nominees for an Amateur Association Board position must pay their IQHA membership and Amateur dues for the following year prior to the closing date for nominations. Failure to comply may result in removal from office.

Amateur Association Rules

A. General

1. DIVISIONS (Junior Division: 19-34 years of age; Senior Division: 35 years of age & older) —

Exhibitors in this division must be 19 years of age or older, or under 19 and married, divorced, or widowed, and not eligible for YA classes, and not having engaged in any activities during the past three calendar years which would make them ineligible for amateur status. Age as of January 1 of show year is age for the entire year.

2. OWNERSHIP — Horses owned by the exhibitor or a member of their immediate family are eligible to be shown in this division. Farm, ranch or corporation ownership is permissible if owned solely by members of the immediate family. Such ownership must be evidenced by the records of this association and the horse's registration certificate at the time the horse is entered in any Amateur class.

3. LEASED HORSES — Leased horses are eligible in this division provided a IQHA Lease Notification form has been filed, along with the appropriate fees, at the IQHA office.

4. COMPETITIVE UNIT — A competitive unit shall consist of one amateur and one IQHA-registered animal. Points will not be combined with two or more animals. Points may not be transferred from one animal to another.

5. Horses may cross enter between youth, amateur and open classes at the same show.

6. Only those persons holding current IQHA amateur cards or having applied for same, may enter amateur classes at approved IQHA ROM shows.

7. Only Quarabs that are owned or leased as defined in paragraphs A.2. and A.3. above are eligible to be shown in this division.

B. Amateur Status

1. For horse show purposes, a person is considered an Amateur by IQHA when he or she is no longer eligible to compete in youth activities classes and does not receive remuneration or barter, directly or indirectly, for:

a. Riding, driving, showing in halter, training, schooling, or conducting clinics or seminars.

b. Giving instruction in equitation or horse training.

c. The use of their name, photograph, or other form of personal association as a horseman in connection with any advertisement or written article to be sold.

d. Holding a judge's card with any organization recognized by IQHA or AHSA.

e. Writing books or articles pertaining to horses.

2. The following activities shall not affect the amateur status of a person who is otherwise qualified:

a. Having the occupation of veterinarian or farrier, or owning a tack store or breeding or boarding stable do not in themselves affect the amateur status of a person who is otherwise qualified.

b. IQHA amateurs may derive income from driving commercial horses (i.e., Carriage horses) without affecting their amateur status.

c. IQHA amateurs may judge open shows and 4-H shows as long as they do not hold a judge's card in organizations the IQHA Judges Committee recognizes (i.e., AQHA, APHA, ApHC, USA Equestrian, etc.), and as long as they do not receive remuneration or barter, directly or indirectly, in any form.

3. Any person who, under these rules, does not qualify for amateur or novice amateur status and shall knowingly and falsely represent themselves to be an amateur in order to show in halter, or ride or drive in amateur or novice amateur classes, or any person who violates any of the provisions of this rule shall be subject to disciplinary action. This will be followed by a mandatory three (3) full calendar year (Jan-Dec) waiting period before re-applying for amateur or novice amateur status.

4. All competitors in this division must annually file a Statement of Amateur Status and application for an Amateur card with IQHA before entering any amateur class. IQHA must be notified in writing of any change of status within thirty (30) days of said change and amateur activities shall cease immediately.

5. Payback in AM classes

a. Weekend high-point awards may be paid to amateurs.

b. IQHA amateur members may accept class payback and cash highpoint awards without jeopardizing their IQHA amateur status. Individuals are encouraged to check with any other organizations with which they may be involved for clarification on how this rule effects their amateur status in that organization.

6. All inquiries concerning amateur eligibility status must be directed through the IQHA office and approved by the IQHA Executive Manager, after which they will be referred to the Amateur Eligibility Review Board, comprised of the Amateur Association Executive Board.

7. Before applying/re-applying for amateur status, a person who is ineligible for amateur status must serve

a waiting period of three (3) full calendar years (Jan-Dec), after the date of the last activity that made them ineligible.

C. Membership

All competitors in this division must be current members of IQHA and must have a current IQHA Amateur card or have applied for same, for the competitive unit to exhibit and receive any awards in this program.

D. Classes

1. AM classes at halter may be offered. (i.e., AM Geldings, AM Mares) This may be divided by age and/or type.
2. Amateur classes shall consist of those listed as approved point-earning events, except for Track Racing, Stock Saddle Racing, Competitive Riding, Endurance Riding, and Combined Training.
3. Additional point-earning amateur events shall be in Equitation and Showmanship.
4. Western and English events (i.e., showmanship) may not be combined.
Hunter and Saddle Seats may be combined in English Pleasure and Equitation, but Western and English seats may not be shown together, except in Novice Showmanship, Novice Walk/Trot, and Trail.
5. If entries warrant, amateur classes may be divided by age of exhibitors into 19-34 and 35 and over divisions. Additionally, an age division may be divided at the discretion of the show committee as long as the split in the ages remains within the age division (i.e. Jr. split within Jr. division and Sr. split within Sr. division).
6. To be eligible for points, all class titles must be preceded by the designation "AM."

E. Awards

Amateur competitors may earn awards based on amateur qualifications. Amateur of the Year awards will be given for Jr. & Sr. amateurs.

F. Novice Amateur Program

1. The purpose of the Novice Amateur Program is to aid in raising the competencies and confidence level of the person who has little or no experience in the show ring or is new to riding/handling horses. It is open to any IQHA amateur who possesses a IQHA amateur card. A Novice Amateur is a person who has not earned a Quarab or any equine registry Showmanship or Performance ROM or its equivalent, or earned a total of more than 20 points within a category, as defined by IQHA Novice Amateur rules. The year in which the novice amateur achieves either 20 points or any Quarab or equine registry ROM in a

category will be the last year of novice amateur eligibility in that category.

a. The Novice Amateur categories are as follows:

AM Novice Showmanship - English/Western
AM Novice Walk/Trot - English/Western
AM Novice English Pleasure or Equitation
AM Novice Western Pleasure or Stock Seat Equitation

AM Novice Trail - English/Western

2. Points in the Novice Program do not count toward any IQHA awards. There will be no ROM's presented in novice amateur classes. A Notice of Advancement will be awarded to those who advance out of a Novice Amateur category. All Quarab Amateur ownership/membership requirements apply to the Novice Amateur Program.

3. An Amateur card with a Novice notation will be issued to each person who supplies IQHA with a signed Eligibility Statement.

4. Novice Amateurs are governed under the Amateur Association Rules and Regulations and are subject to review and disciplinary action as covered by these rules.

G. AM Novice Showmanship - English/Western

1. To be judged on the same point or percentage basis as other IQHA Showmanship classes. Appointments and attire may be English or Western, but must be consistent with Showmanship class rules. Judge may require exhibitor to perform a pattern.

H. AM Novice Walk/Trot - English/Western

1. Horses must walk and trot both ways of the ring. Horses may not lope/ canter. They may be required to back. Appointments and attire may be English or Western, but must be consistent with style of riding. Chaps are optional to the Western exhibitor. Novice walk/trot Amateurs may not cross enter any class (open or amateur) requiring a lope/canter at the same show.

I. AM Novice English Pleasure or Equitation - Hunter/Saddle Seats

1. To be judged on the same point or percentage basis as existing IQHA Hunter/Saddle Seat English Pleasure or Equitation rules.

J. AM Novice Western Pleasure or Stock Seat Equitation

1. To be judged on the same point or percentage basis as existing IQHA Western Pleasure or Stock Seat Equitation rules.

K. AM Novice Trail - English/Western

1. To be judged on the same point or percentage basis as existing IQHA Trail rules.

RULE 86

Showmanship at Halter

Restricted to AM and/or YA classes only.

A. General

- 1.** The handler of the Quarab is judged on their ability to present a horse at halter to its greatest advantage. Only the showman is judged. The Quarab is merely a prop used to show the ability of the handler.
- 2.** The conduct of the classes shall be at the judge's discretion and direction.
- 3.** The call judge's instructions to exhibitors and Showmanship patterns must be publicly posted prior to class. (It is recommended that multiple judge shows designate one judge as call judge.)

B. Appearance

- 1.** 10% — Attire should be neat, clean and well-fitting. A workmanlike appearance should be presented. A hat is required in all classes. Spurs are prohibited in all classes. Attire should reflect the use of the Quarab and should be consistent with the tack used on the Quarab.
- 2.** 5% — Tack should be neat, clean & in good repair.

C. Grooming and Fitting of Animal

- 1.** 15% — Condition and thriftiness
- 2.** 15% — Grooming: hair coat clean and well-brushed. Mane and tail clean and free of tangles. Feet properly trimmed. If shod, the shoes must fit the Quarab properly and clinches should be neat.
- 3.** 5% — Trimming: mane and tail trimmed properly for the conformation type and style of showing. Inside of ears may be trimmed, along with long hair on jaw, legs and pasterns.

D. Presentation of Animal

- 1.** 15% — Leading
 - a.** Enter ring leading Quarab at an alert walk in a counter-clockwise direction (unless otherwise directed). Allow at least one animal length between entries. Walk on Quarab's left side, holding lead shank or rein in the right hand a reasonable distance from halter or bridle. Remaining portion of the shank or rein to be held neatly and safely in the left hand. Animal should lead readily at a walk.
 - b.** After the class has lined up, the judge will call on each exhibitor to move their Quarab individually. When moving the Quarab, be certain the judge can get a clean, unobstructed view of its action. The Quarab should move freely and in a straight line. Horses are always turned to the right.
- 2.** 15% — Posing
 - a.** A Quarab should be set up with a minimum of fuss. Stand toward the front, facing the Quarab, always in a position where you can see the judge and where he/she can see the Quarab. Never kick an animal's leg

into position. Watch for the judge to approach and have the Quarab alert, standing to its best advantage for the judge's examination.

b. Do not crowd the exhibitor next to you when in a side by side position. Do not crowd the exhibitor in front when lined up head to tail. When the judge is observing other Quarabs, let yours stand if posed reasonably well. Be natural. Overshowing, undue fussing and maneuvering are objectionable.

3. 20% — Poise

a. Keep alert and know the position of the judge at all times. Do not be distracted by activities or persons outside the ring. Show the Quarab at all times, not yourself. Recognize quickly and correct faults of your Quarab.

b. Be courteous and sportsmanlike at all times. Respond quickly to requests from the judge or ringmaster. Keep showing the entire duration of the class.

E. Western Showmanship

- 1.** Animals shall be shown in a halter with lead shank. Leather equipment is suggested and preferred over other materials. Silver is optional. Whips or crops are prohibited.
- 2.** Animals used in a Western Showmanship class shall stand according to their conformation type regulations. A judge may ask a Showmanship exhibitor to square up their Quarab for individual inspection. A Quarab posed in any other manner shall be marked down.
- 3.** In Western Showmanship, any type of horse may be braided or banded.

F. English Showmanship

- 1.** Animals shall be shown in a halter with lead shank, show bridle with lead shank, a snaffle bridle or curb bit. In all cases, leather equipment is suggested and preferred over other materials.
- 2.** Whips or crops are optional. A whip shall not be used as a substitute for proper training. Exhibitors shall be penalized for actions with a whip that disturb any other exhibitor.
- 3.** Exhibitors shall be dressed in either Hunter Seat or Side Saddle clothing. Attire must be consistent with the tack used on the Quarab.
- 4.** Animals used in an English Showmanship class must be shown according to their conformation type regulations.
- 5.** In English Showmanship, any type of horse may be braided.

RULE 87

Equitation

Restricted to AM and/or YA classes only.

A. General

1. The equitation division is divided into two distinct sections – Stock & Hunter Seats. In equitation classes, only the rider is being judged. Animals, attire, and equipment must be consistent with class specifications.

2. Any rider not having their mount under sufficient control shall be dismissed from the ring and shall be disqualified from that class. In Hunter Seat Equitation Over Fences, the fall of mount or rider shall eliminate a contender. In Stock Seat & Hunter Seat on the flat classes, the fall of mount or rider shall not necessarily eliminate, but may be penalized at the judge's discretion.

3. No attendant shall be allowed in the ring except at the request of the judge.

4. The call judge's instructions to exhibitors and Equitation patterns shall be publicly posted prior to class.

5. When additional tests are desired, the judge's instructions to riders should be publicly announced.

6. Pattern work may be worked first. If the pattern includes a walk, jog/trot, lope/canter, and a back, the call judges may elect not to work the class on the rail.

7. Junior horses shown in a bosal or snaffle bit may be ridden with two hands in Equitation classes.

8. In Equitation classes, individual patterns are not required if judge includes test in rail work.

B. Stock Seat Equitation

1. Appointments — Clothing must be clean, workmanlike and neat. The saddle must fit the rider. It may be slick or swelled fork, have a high or low cantle, but must definitely be sized to the rider. Attire and equipment shall be the same as in Western. Nothing that would prevent the stirrups from hanging freely shall be added to or deleted from a standard western saddle.

2. Hands — In repose, arms are in a straight line with body, the one holding reins bent at elbow. Only one hand is to be used for reining and hands shall not be changed. Hand to be around reins. When ends of split reins fall on near side, one finger between reins is permitted. When using romal or when ends of split reins are held in hand not used for reining, no finger between reins is allowed. The position of the hand not used for reining is optional, but it should be kept free of horse and equipment and held in a relaxed manner, with the rider's body straight at all times. Rider may hold romal or end of split reins to keep from swinging and to adjust the position of the reins, provided it is held at least 16 inches from the reining hand. Hands to be above horn and as near to it as possible. Bracing against horn or coiled reata or rope will be penalized.

3. Basic position — The rider should sit in the saddle in a balanced, relaxed manner, with legs hanging straight and slightly forward to the stirrups. The stirrup should be just short enough to allow heels to be lower than toes. Body always should appear comfortable, relaxed and flexible. Feet should be placed in the stirrups with weight on ball of the foot. Consideration, however, should be given to the width of the stirrups, which vary on western saddles. If stirrups are wide, the foot may have appearance of being "home" when, in reality, the weight is being properly carried on the ball of the foot.

4. Position in Motion — Rider should sit to jog and not post. At the lope, he/ she should be close to saddle. All movements of horse should be governed by the use of imperceptible aids. The shifting of rider's weight is not desirable.

5. Class Routine — If pattern is not worked first, enter the ring at a walk or jog and are to be judged at a flat-footed four beat walk, jog and lope. They shall be worked out both ways of the ring and shall always be on the correct lead. The order to reverse may be executed by turning either towards or away from the rail. Due to difficulty of properly fitting the tack, riders shall not be asked to change mounts. Animals shall be required to back in a straight line in all classes.

6. Additional Work — Riders will perform not only the ring routine demanded of them, but also should be able to perform whatever additional tests from those listed below the judge may deem advisable to ask of them. Tests may be performed either collectively or individually, but no other test may be used.

a. Individual performance on the rail.

b. Figure eight at a jog.

c. Lope and stop.

d. Figure eight at lope on correct lead, demonstrating simple change of lead. (This is a change whereby the Quarab is brought back into a walk or jog and restarted into a lope on the opposite lead.) One figure eight demonstrates two changes of lead and is completed by closing up the last circle and stopping in the center of the eight.

e. Ride without stirrups.

f. Figure eight at lope on correct lead, demonstrating flying change of lead.

g. Change leads down center of ring, demonstrating simple change of lead.

h. Ride serpentine course, demonstrating flying change of lead at each change of direction.

i. Demonstrate sliding stop.

j. Execute 360° turns (spins).

k. Roll backs.

7. Riders to be judged on seat, hands, performance of mount, appointments of mount and rider and suitability of mount to rider. Good hands are

paramount. Results as shown by the performance of the mount are not to be considered more important than the method used in obtaining them.

C. Hunter Seat Equitation

1. Appointments/Attire — Clothing must be clean, workmanlike and neat.

The saddle must fit the rider. Attire and equipment shall be the same as in Hunter Seat. A judge, at their own discretion, may penalize a Quarab with non-conventional types of bits or nose bands. Boots or bandages are prohibited in all classes and martingales are prohibited in classes not to jump (flat classes). Spurs must be of the unrowelled type. Crops or bats optional.

2. Hands — Hands should be over and in front on Quarab's withers, knuckles 30° inside the vertical, hands slightly apart and making a straight line from Quarab's mouth to rider's elbow. Method of holding reins is optional and bight of reins may fall on either side. However, all reins must be picked up at the same time.

3. Basic position — The eyes should be up and shoulders back. Toes should be at an angle best suited to rider's conformation; ankle flexed in, heels down, calf of leg in contact with Quarab and slightly behind girth. Iron may be either on toe, ball of foot or "home".

4. Position in Motion — At the walk and slow trot, body should be vertical; posting trot, inclined forward; canter, half way between the posting trot and the walk; galloping and jumping, same inclination as the posting trot.

5. Mounting and Dismounting — To mount, take up reins in left hand and place hand on withers. Grasp stirrup leather with right hand and insert left foot in stirrup and mount. To dismount, rider may either step down or slide down. The size of rider must be taken into consideration.

6. Class Routine — When not to jump, or, if pattern is not worked first, contestants shall enter ring, and shall proceed around ring at each gait and, on command, reverse and repeat. Riders may be asked to work collectively without irons. The order to reverse may be executed by turning either towards or away from the rail. Light contact with Quarab's mouth is required. When class is over fences, the performance begins when the Quarab enters the ring or is given the signal to proceed after entering the ring. Except for refusals, jumping faults of the Quarab are not to be considered unless it is the result of the rider's ability. A refusal, loss of stirrup or trotting while on course when not part of a test constitute major faults and may be cause for elimination. Each contestant may circle once if desired before approaching first jump. He/she shall then proceed around course, keeping an

even pace throughout. Three cumulative refusals will eliminate. If a refusal occurs in a double or triple, riders shall rejump all elements of the combination.

7. Additional Work — Riders will perform not only the ring routine demanded of them, but also should be able to perform whatever additional tests from those listed below the judge may deem advisable to ask of them. All tests must be performed on the flat. Tests may be performed either collectively or individually, but no other test may be used.

a. Back.

b. Hand gallop and halt.

c. Figure eight at canter on correct lead, demonstrating simple change of lead. (This is a change whereby the Quarab is brought back into a walk or trot and restarted into a canter on the opposite lead.) Figures to be commenced in center of two circles so that one change of lead is shown.

d. Disengage feet from irons. Ride without irons for a brief period of time. No more than one minute at the trotting pace. Engage feet in irons.

e. Dismount and mount.

f. Turns on the forehand.

g. Figure eight at canter on correct lead, demonstrating flying change of lead.

h. Execute serpentine at a trot and/or canter on correct lead, demonstrating simple or flying changes of lead.

i. Change leads down center of ring, demonstrating a simple or flying change of lead.

j. Canter on counter lead. No more than twelve Quarabs may counter Canter at one time.

k. Turns on the haunches.

8. Riders to be judged on seat, hands, performance of mount, appointments of mount and rider and suitability of mount to rider. Riders should have a workmanlike appearance, seat and hands light and supple, conveying the impression of complete control should an emergency arise.

D. Bareback Equitation

General — Bareback Stock Seat Equitation, Bareback Hunter Seat Equitation and Bareback Saddle Seat Equitation will count for Youth and Amateur ROM points.

Bareback Hunter Seat Equitation and Bareback Saddle Seat Equitation may be combined at the discretion of the show management.

E. Bareback Stock Seat Equitation

1. If pattern is not worked first, enter the ring at a flat-footed walk, turning to the right and proceeding in a counter-clockwise direction. The class will be worked at a walk, jog-trot and lope, both directions of the ring, on a reasonable loose rein without undue restraint. The class may be asked to extend normal gaits, mount and dismount, back, work individually or

perform other tests the judge may deem necessary to determine the extent of the rider's horsemanship. Riders 13 years of age and under will not be required to mount and dismount.

2. The rider is judged on their ability to ride and control a horse properly without the use of a stock saddle. A rider shall be judged on their basic positions: hand, leg, seat and back positions. A rider should sit in a balanced, relaxed manner, up close to the horse's withers, keeping the back straight and shoulders even. A rider should keep their arms in close to the body. The rein hand (one finger between the reins is permissible) should be held loosely and should be positioned directly above and in front of where the saddle horn would be if the rider were using a saddle. The position of the rider's free hand is optional, but should indicate a relaxed, not sloppy, balanced attitude of the body and should be kept free of the horse except that rider may hold romal to keep it from swinging and to adjust the position of the reins, provided it is held at least 16" from reining hand. The legs maintain contact with the horse, giving the necessary leg grip. The foot is turned out slightly and the heels should be level or slightly lowered close to the horse, just behind the horse's elbows. A rider should be in balance with their horse at all times and should be able to sit the trot bareback. No posting at the trot will be permitted. An imaginary straight line drawn from the rider's shoulders or hip should drop at the back of the heel and a straight line from the knee should drop in front of the toe. A rider in this class must be able to display their knowledge of how to handle a horse properly through their riding ability in the ring. A rider is penalized if he/she uses two hands on the reins, changes hands on the reins, touches any part of the horse with their free hand, falls off their horse, or if the horse falls down. A fall will be considered when the horse's shoulder and haunch on the same side touch the ground. A fall is a disqualification. While the horse is in motion, the rider's hands shall be clear of the horse.

3. Appointments — Required personal appointments: The rider must enter the arena wearing a western hat, long sleeved shirt, long pants and cowboy boots. Chaps are prohibited.

4. For additional work, refer to Stock Seat Equitation rules.

F. Bareback Hunter Seat Equitation

1. Appointments — Proper Hunter Seat attire is required for the rider.

Clothing must be clean, workmanlike and neat. Attire and equipment shall be the same as in Hunter Seat except no saddle is used. A judge, at their own discretion, may penalize a Quarab with non-conventional types of bits or nose bands. Boots or

bandages are prohibited in all classes. Spurs must be of the unrowelled type. Crops or bats not to exceed 48" are optional.

2. Hands — Hands should be over and in front of Quarab's withers, knuckles 30° inside the vertical, hands slightly apart and making a straight line from the Quarab's mouth to the rider's elbow. Method of holding the reins is optional and bight of reins may fall on either side. However, all reins must be picked up at the same time.

3. Basic Position — The eyes should be up and shoulders back. Toes should be at an angle best suited to rider's conformation, ankles flexed in, heels down, calf of leg in contact with Quarab and slightly behind the horse's girth.

4. Position in Motion — At the walk and sitting trot, body should be vertical; posting trot, inclined forward; canter, half way between the posting trot and the walk; galloping and jumping, same inclination as the posting trot.

5. Mounting and Dismounting — To mount, take reins in left hand and place hand on withers. To dismount, rider may slide down. The size of the rider must be taken into consideration. Riders 13 and under will not be required to mount and dismount..

6. Class Routine — Refer to Hunter Seat Equitation Classes.

7. Additional Work — Refer to Hunter Seat Equitation Classes.

8. Rider to be judged on seat, hands, performance of mount without saddle, appointments of mount and rider and suitability of mount to rider. Riders should have a workmanlike appearance, seat and hands light and supple, conveying the impression of complete control should any emergency arise.

H. Reinsmanship (Driving Equitation) Amateur & Youth ONLY

A Pleasure Driving class in which the entries are judged primarily on the ability and skill of the driver. To be shown at a walk, slow trot (collected), working trot (normal) and strong trot (extended). Drivers shall be required to rein back. All drivers chosen for a work out may be worked at any gait requested by the judge and may be asked to execute a figure eight.

1. To be judged;

a. 75% on handling of reins and whip, control, posture, and overall appearance of the driver.

b. 25% on the condition of the harness and vehicle and neatness of attire.

c. The Quarab is to be shown in a harness suitable to the vehicle used. The vehicle should be an appropriate two/four wheeled vehicle with wire or wooden wheels and in sound condition. (Refer to Rule 79 in the International Quarab Horse Association Rule Book).

2. Appointments of driver and attendant (header); the driver and attendants (if any) should be dressed conservatively according to the style of the present day. Suggested attire for gentlemen, dress pants and shirt, coat or jacket and boots. Suggested attire for ladies; dress tailored suit, skirt or slacks, and blouse, best or jacket, and boots. The following attire is required of all drivers; hat or protective headgear, gloves and whip in hand. Lap apron or robes are optional. Attendants should wear long pants, shirt and boots. Attendants are optional.

RULE 88

Miss Quarab Of America

A Queen is selected each year at the **World Championship Show**. Contact the IQHA office for rules and information.

RULE 89

Stock Saddle Racing

A. General - For complete rules and regulations, contact the IQHA Business Office.

RULE 90

Track Racing

A. General - For complete rules and regulations, contact the IQHA Business Office.

RULE 91

Endurance Riding

A. General

1. All Endurance Rides accepted for points must be conducted under the rules of the American Endurance Ride Conference (AERC) or other responsible association charged with the supervision and conduct of such competitions.

2. For IQHA points to be earned by registered Quarabs, a minimum ride shall be 25 miles with no minimum time limit. Vet requirements to be in accordance with the rules of the ride. Horses must pass all check points satisfactorily. Drugs or inhumane equipment prohibited. Horses must be at least four years old for 50 mile rides and at least five years old for 100 mile rides.

B. Points

1. Points for Endurance rides shall be computed on the following basis:

a. Completion — Four (4) points, when within maximum time limit.

b. Time — Two (2) points for every 10 horses, or major portion thereof, finished faster than. (Count even non-finishing entries.)

c. Placing — Same as the regular ROM point scale.

d. Condition — Six (6) points for best conditioned of all horses; Five (5) points for top five (5) best conditioned.

e. Bonus

(1) Three (3) points for best time registered Quarab, if given.

(2) Three (3) points for best condition registered Quarab.

f. Double Score — double the total of (a) thru (e) above if ride is 100 miles or more in two days.

g. Triple Score — triple the total of (a) thru (e) above if ride is 100 miles or more in one day.

C. Distance

1. A certificate of special recognition will be issued to a Quarab for every 250 miles of competition completed according to IQHA records.

RULE 92

Competitive Riding

A. General

1. All Competitive Rides accepted for points must be conducted under the rules of the North American Trail Ride Conference (NATRC) or other responsible association charged with the supervision and conduct of such competitions.

2. For IQHA points to be earned by registered Quarabs, a minimum ride shall be 25 miles with no minimum time limit. Vet requirements to be in accordance with the rules of the ride. Horses must pass all check points satisfactorily. Drugs or inhumane equipment prohibited. Horses must be at least four years old for 50 mile rides and at least five years old for 100 mile rides.

B. Points

1. Points for competitive riders shall be computed on the following basis:

a. Completion — Four (4) points, when within maximum time limit.

b. Placing — Same as the regular ROM point scale.

c. Finishing — Two (2) points for every 10 horses, or major portion thereof, finished faster than. (Count even non-finishing entries.)

d. Bonus

(1) Two (2) points — Sweepstake.

(2) Two (2) points — High scoring registered Quarab.

(3) Two (2) points — Score of 88 or more, per NATRC.

(4) Double score for a 2-day ride.

C. Distance

1. A certificate of special recognition will be issued to a Quarab for every 250 miles of competition completed according to IQHA records.